



100 Years of Reliability & Precision

OKK CORPORATION

Horizontal Machining Center

HM SERIES

HM 400

HM500S

HM 5100

HM6000S

HM 630

HM800S

HM 800

HM1000S

HM1000

HM1250S



HM Series Horizontal Machining Centers

HM-series horizontal machining centers are built with OKK's exceptional designs and provided with superior performance ensuring high-speed machining, rigidity, reliability, and chip evacuation. Heavy cutting capability is just one of HM-series specialties achieved by incorporating a highly developed rigid box-shaped frame.

Add to that the implementation of only the best in high-speed motors, and extremely reliable ATC's (auto tool changer) and APC's (auto pallet changer) that deliver minimal chip to chip time, truly merging max performance with production proven reliability.



**HM400
HM500S**

Main specifications

HM400/40, HM400/50

Travel X x Y x Z mm (in) = 630 (24.80) x 620 (24.41) x 710 (27.95)
Rapid traverse rate m/min (ipm) = 54 (2,126)
Pallet size square mm (in) = 400 (15.75)

HM500S/40, HM500S/50

Travel X x Y x Z mm (in) = 630 (24.80) x 620 (24.41) x 710 (27.95)
Rapid traverse rate m/min (ipm) = 54 (2,126)
Pallet size square mm (in) = 500 (19.69)

* /40: BT40 type, /50: BT40 type

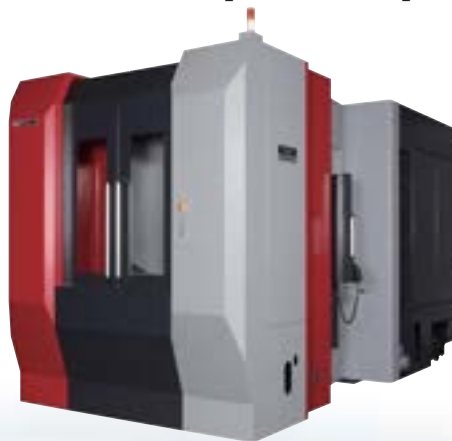

**HM5100
HM6000S**

Main specifications

HM5100

Travel X x Y x Z mm (in) = 800 (31.50) x 750 (29.53) x 880 (34.65)
Rapid traverse rate m/min (ipm) = [Std] XZ: 75 (2953), Y: 60 (2362)
Pallet size square mm (in) = 500 (19.69)

HM6000S

Travel X x Y x Z mm (in) = 800 (31.50) x 750 (29.53) x 880 (34.65)
Rapid traverse rate m/min (ipm) = [Std] XZ: 75 (2953), Y: 60 (2362)
Pallet size square mm (in) = 630 (24.8)



**HM630
HM800S**

Main specifications

HM630

Travel X x Y x Z mm (in) = 1050 (41.34) x 900 (35.43) x 900 (35.43)
Rapid traverse rate m/min (ipm) = [Std] 54 (2126)
= [Opt] 75 (2953)

Pallet size square mm (in) = 630 (24.8)

HM800S

Travel X x Y x Z mm (in) = 1050 (41.34) x 900 (35.43) x 880 (34.65)
Rapid traverse rate m/min (ipm) = [Std] 54 (2126)
= [Opt] 75 (2953)

Pallet size square mm (in) = 800 (31.5)

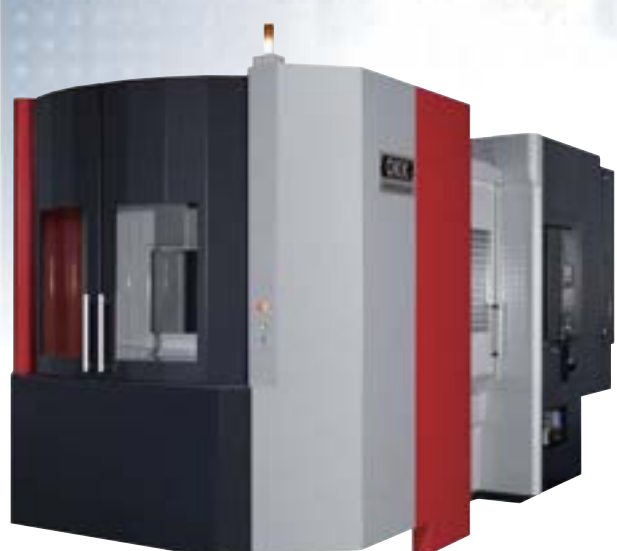

HM800 HM1000S

Main specifications

HM800
Travel X x Y x Z mm (in) =1400(55.12)x1100(43.31)x1050(41.34)
Rapid traverse rate m/min (ipm) = 48(1889)
Pallet size square mm (in) =800(31.5)

HM1000S
Travel X x Y x Z mm (in) =1400(55.12)x1100(43.31)x1000(39.37)
Rapid traverse rate m/min (ipm) = 48(1889)
Pallet size square mm (in) =1000(39.37)

HM1000 HM1250S

Main specifications

HM1000
Travel X x Y x Z mm (in) =1700(66.93)x1400(55.12)x1400(55.12)
Rapid traverse rate m/min (ipm) = 48(1889)
Pallet size square mm (in) =1000(39.37)

HM1250S
Travel X x Y x Z mm (in) =1700(66.93)x1400(55.12)x1240(48.82)
Rapid traverse rate m/min (ipm) = 48(1889)
Pallet size square mm (in) =1250(49.21)

[Std] Standard equipment or function
[Opt] Optional equipment or function

CONTENTS

Main features	P01	ATC(Automatic tool changer)15	Controller	P31
Features	P03	Powerful feeding16	F31i-B.....31	
Chip disposal06		Accuracy17	FAi 32	
High speed and heavy-duty cutting07		Cutting capacity18	Specifications	P33
Spindle power and		Operations.....19	HM400/HM500S33	
torque diagram09		Maintenance.....20	HM5100/HM6000S35	
Pallet table and APC 11		Standard and option list....21	HM630/HM800S37	
High precision structure....12		Option	HM800/HM1000S39	
Tool magazine13		P22	HM1000/HM1250S41	
		Software29		

HM400/HM500S

With more rigid construction than conventional models, responding to the needs to machining a wide range of products from iron and cast iron to mold and die parts.

Not only the rigidity but also spindle speed, rapid traverse, reliability and machining performance have been upgraded.

HM400/40 and HM500S/40 models come equipped with a 10000min⁻¹ spindle, with an output of 37/26/22kW (50/35/30HP) available in BT40 spindle taper, as well as the option for a 15000min⁻¹ or 20000min⁻¹ spindle. HM400/50 and HM500S/50 models have a standard spindle reaching 12000 min⁻¹, with an output of 30/25kW (40/34HP) available in BT50 spindle taper, with an optional 8000min⁻¹. Allows customers the best option for the job.

The unique clamp construction provides excellent sealing performance by clamping while increasing the internal pressure of the table, thus preventing the infiltration of coolant enhancing the durability of the machines.



High rigid linear roller guides are used for all axes of X, Y and Z.

The ball screws are core-cooled ball screws and pre tensioned by double-anchor method. Cooling oil is forced to all ball screws, ball screw support housings and motor mounting surfaces.

The fine-feed movement and the lost motion property have been improved. The circular cutting accuracy is also improved significantly.

Characteristics

- * The machining time is significantly improved by increasing all of speeds.
- * The ball screws are core-cooled ball screws and double anchored.
- * Option of a BT40 is with 10000 min⁻¹ or BT50 with 12000 min⁻¹ is available to meet your machining needs.
- * One piece shutters are used for X and Z axes and avoids chips and coolant going to inside.

(only Z-axis shutter is one piece type for HM400/50 and HM500S/50.)

HM5100/HM6000S HM630/HM800S HM800/HM1000S

Double the speed, rigidity, reliability, durability, etc. compared with the conventional machines enable high-speed and high-accuracy machining of wide-ranging materials including hard-to-cut materials such as ferrous and casting materials.

In addition to the high rigidity of the machine main unit, highly-rigid linear roller guides on the X, Y and Z axes generate a synergetic effect and improve further the cutting performance.

Increase in the rapid-traverse rates, ATC speed, table turning speed and APC speed has shortened the non-cutting time and improved production efficiency.

For the improved heavy-duty cutting performance, the machine has a BT50 large-diameter $\phi 100\text{mm}$ (3.94") spindle and a 45/30/26kW (60/40/35HP) high-power motor.



Built - in - Rotary Table (BRT) use a new mechanism of precision reduction-gear roller drive. This drive system achieved high speed table indexing and toughness against overload or impact. *1

Pallet positioning and clamping
Use of taper cones ensures high accurate repeatability of pallet positioning and flatness of the pallet is secured by means of OKK's original design multiple-clamp method.*2

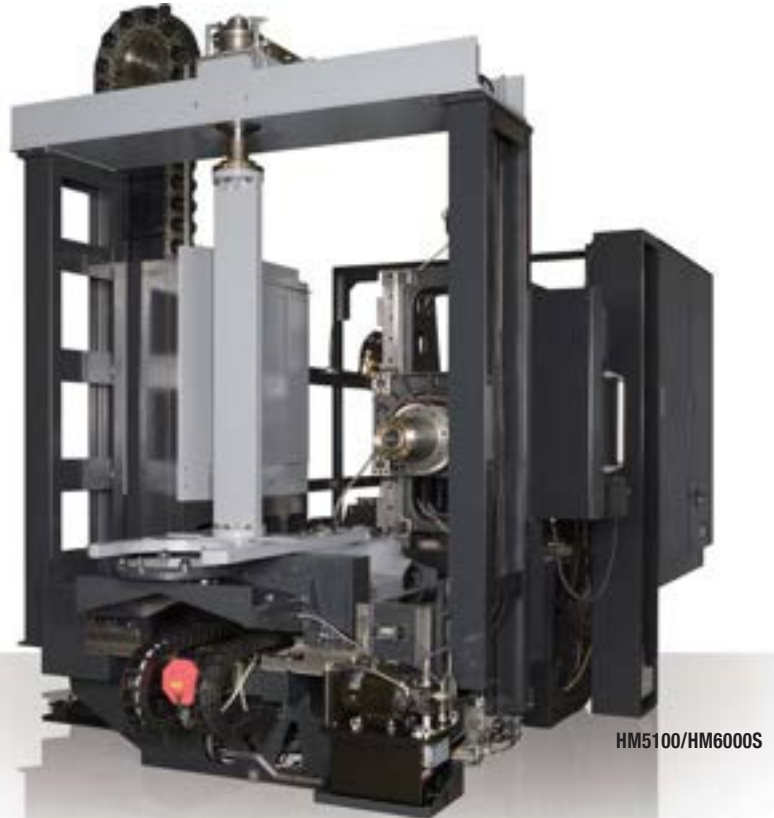

HM5100/HM6000S

Master pallet is available as option.*3

Characteristics

- * Linear roller guides are capable the six times more moment load than a conventional model.
- * BRT use the high speed and high rigid reduction-gear roller drive that is more than double the rigidity and clamping torque compared to a conventional model. *1

Specifications	Spindle speed (min ⁻¹)	Type of tool shank	Spindle bearing inner diameter (mm)	Rapid traverse rate (m/min)
HM5100/HM6000S	12000	BT50	$\phi 100$ (3.94")	75 (2953 ipm)*5
HM630/HM800S				54 (2126 ipm) [Opt. 75 (2953 ipm)]*5
HM800/HM1000S	8000			48 (1889 ipm)

*1: HM800/HM1000S and HM1000/HM1250S use worm shaft and worm wheel. *2: HM400/HM500S is using center-clamping method. *3: Master pallet is available only for HM5100/HM6000S.

*4: Additional option available rapid traverse rate to 75m/min(2953ipm) for X-axis and Z-axis. *5: An air tank is necessary to attach a balance cylinder to Y axis. The air tank needs local procurement at machine export.

HM1000/HM1250S

All HM models are highly effective in machining cast-metal and iron-based work pieces, including construction machinery parts, such as cylinder blocks with massive valves requiring maximum rigidity for custom tooling and large molds.

Adopting twin-ball-screw drives and synchronously control for the Y and Z axes, suppresses vibrations and improves machining quality.

Furthermore for severe heavy-duty cutting, a larger spindle bearing diameter of 120 mm (4.72") with maximum spindle speed of 8000 min^{-1} , high-power spindle motor of 37/30 kW (50/40HP) and high-torque motorized spindle of 1009 $\text{N}\cdot\text{m}$ (744 $\text{ft}\cdot\text{lbs}$) is available as option on HM1000/HM1250S.



Characteristics

- * HM1000 and HM1250S models standard spindle delivers 12000min^{-1} , with a bearing diameter of 100mm (3.94") and 30/25kW (40/34HP), 420N·m (310 ft·lbs) of torque.
- * Twin-ball-screws for both Y-and Z-axes, aiding in vibration dampening yielding extended tool life. The design focus is reduction of machining time, while increasing precision, surface finish, and contouring accuracy. HM-series are proven in high production machining environments and are ready to cut aluminum to cast metals.



Z axis twin-ball-screw

The Z-axis shutters and B-axis are angled sharply, allowing for excellent chip evacuation. Furthermore, OKK added a solid Y-axis shutter to eliminate any problems previously caused from chips clogging on un-maintained slide rails.

Thorough chip processing measures

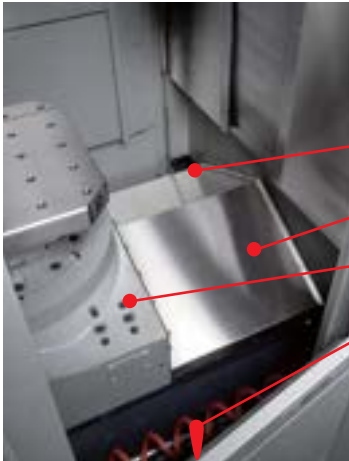

HM400/M500S

- Coil conveyor *2
- Z-axis shutter
- Table body
- Coil conveyor *2

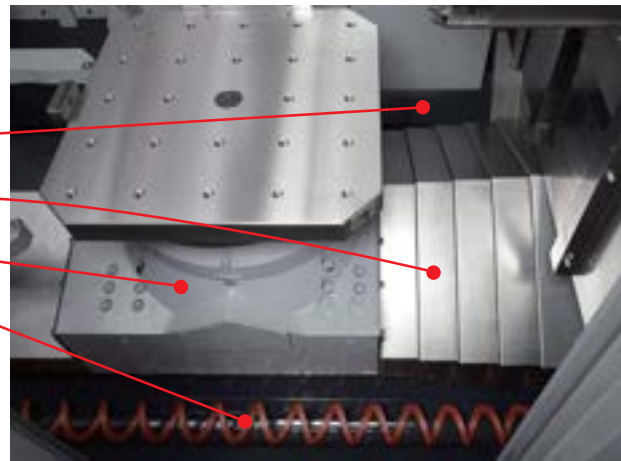

HM5100/HM6000S

Chips are flushed so that they fall into the troughs on both sides of the table. Then, the chips are flushed out with coolant supplied through the nozzles provided in the front-end section of each trough. The coolant and chips are collected in the chip tank in the rear part of the machine (Chip flow coolant *1). In place of the standard method that flushes out chips with coolant, you may use optional coil-type chip conveyor *2 to clear the troughs and to discharge chips through the outlet in the rear part of the machine.

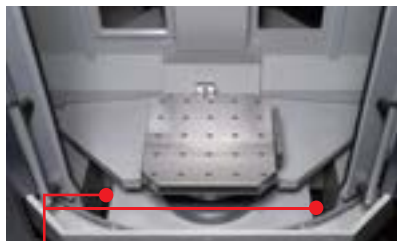
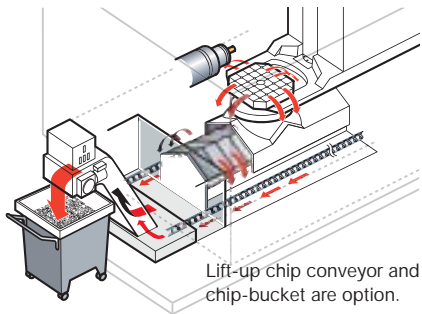

The troughs are extended and chips at the setup station can be collected.

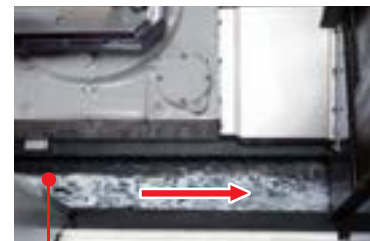

Chip flow coolant *1

Chips are discharged from the troughs to outside of machine by big volume of coolant.

*1: Standard for HM400/HM500S, HM800/HM1000S.

*2: Standard for HM5100/HM6000S, HM630/800S, HM1000/HM1250S.

Ceiling shower [Opt]*3

Coolant through nozzles on the ceiling i.e. ceiling shower can be provided optionally for prevention of chips from accumulating on fixtures and workpieces.

*3: Standard for HM5100/HM6000S.

26 nozzles for HM400/HM500S

27 nozzles for HM5100/HM6000S

30 nozzles for HM630/HM800S

50 nozzles for HM800/HM1000S

91 nozzles for HM1000/HM1250S



HM400/HM500S



HM630/HM800S



HM1000/HM1250S

High Speed and Heavy-duty Cutting



HM400/HM500s'
standard spindle specification is motorized spindle, maximum speed 10,000min⁻¹ with grease lubrication, BT40 and 37/26/22kW (50/35/30HP). Optional spindles 15,000min⁻¹ and 20,000min⁻¹ are oil-air lubrication.

Cutting data	
Machine model	HM400/40
Material	S50C
Tool	ø32 mm (1.26") Long end milling
Length of the tool from tool holder nose	130 mm (5.12")
Spindle speed	1300 min ⁻¹
Feed rate	6500 mm/min (256 ipm)
Depth of cut	0.5 mm (0.02")
Width of cut	20 mm (0.79")



The BT50 spindle rotating at 12000 min⁻¹ secures the 45/30/26kW (60/40/35HP) output. For the bearing lubrication, the machine uses the oil-air lubrication. The spindle specification can be selected according to the details of machining.

Cutting data	
Machine model	HM630
Material	S50C
Tool	ø80 mm (3.15") High feed end mill
Spindle speed	600 min ⁻¹
Feed rate	4000 mm/min (157.48 ipm)
Depth of cut	1 mm (0.04")
Width of cut	80 mm (3.15")

Spindle Cooling



Circulating the temperature-controlled oil around the spindle housing minimize the spindle temperature fluctuation.

MS: Motorized spindle

Standard Spindle 10,000min⁻¹

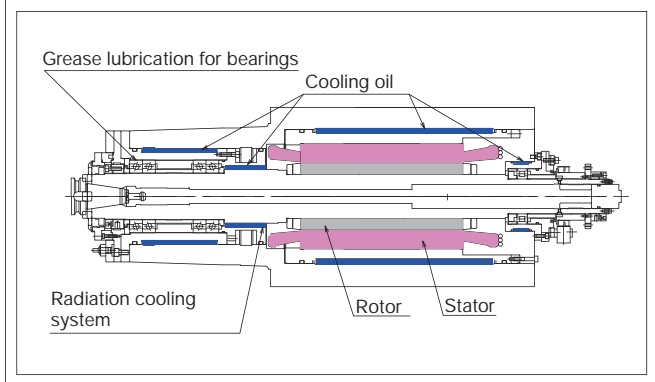

Spindle Cooling



The spindle bearings are oil-air lubricated. Circulating temperature controlled oil is in the groove around the spindle housing suppressing the growth of the spindle. Furthermore, OKK's unique radiant cooling system prevents the conduction of heat generated from the motor into the spindle.

Standard Spindle 12,000min⁻¹

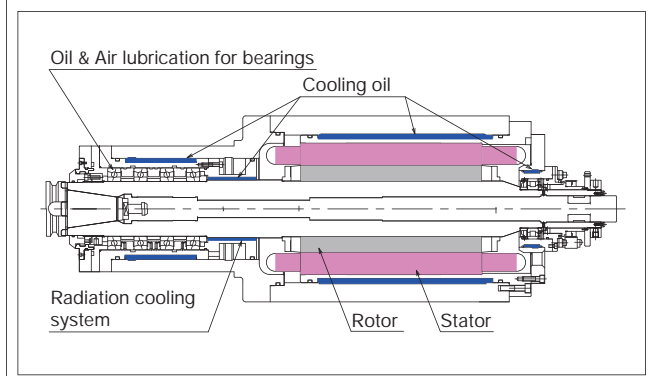

The standard spindle used for **HM800/HM1000S** is the BT50 spindle having the output of 30/25 kW (40/34 HP) and rotating at 8000 min⁻¹. The maximum torque of 420 N·m (310 ft·lbs) can provide high power in the low-speed range. Both the heavy-duty cutting and the high-speed machining are available owing to the highly-rigid spindle with ø100mm (3.94") spindle bearing inner diameter and the oil-air lubrication system.



Cutting data	
Machine model	HM1000S
Material	Mold steel (SKD61)
Tool	ø80mm (3.15") End milling
Length of the tool from tool holder nose	200mm (7.87")
Spindle speed	1600mm ⁻¹
Feed rate	1920mm/min (75.6in/min)
Depth of cut	4.0mm (0.16")
Width of cut	60.0mm (2.36")

● HM630 / HM800S and HM800 / HM1000S Gear-drive spindle [Opt]

Max. torque: 1251N·m (923ft·lbs)

As an option to deliver more torque for machining of hard-to-cut materials, an 8000min⁻¹ high torque gear-drive spindle produces 1251 N·m (923 ft·lbs). Available on HM630/HM800S and HM800/HM1000S.

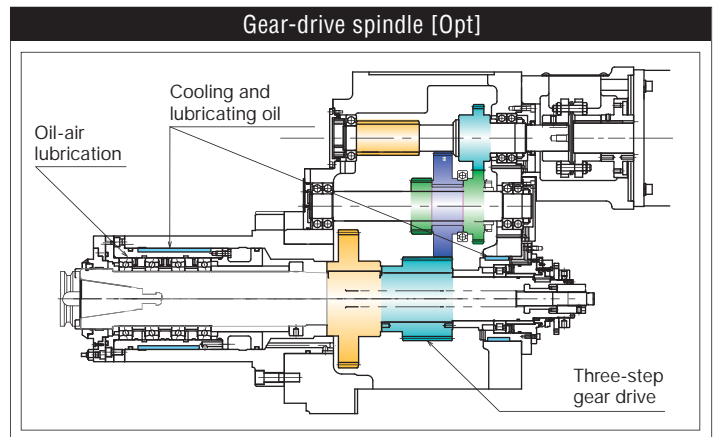

Power of tool clamp

MS spindle			
Machine model	Spindle speed 10000min ⁻¹	Spindle speed 15000min ⁻¹	Spindle speed 20000min ⁻¹
HM400/40, HM500S/40	1000N (2200lbf)	1000N (2200lbf) [Opt]	1000N (2200lbf) [Opt]

MS spindle		
Machine model	Spindle speed 12000min ⁻¹	Spindle speed 8000min ⁻¹
HM400/50, HM500S/50	16300N (3700lbf)	16300N (3700lbf) [Opt]
HM5100/HM6000S	16300N (3700lbf)	—
HM630/HM800S	16300N (3700lbf)	16300N (3700lbf) [Opt]
HM800/HM1000S	16300N (3700lbf) [Opt]	17700N (4000lbf)
HM1000/HM1250S	16300N (3700lbf)	20600N (4600lbf) [Opt]

Gear spindle	
Machine model	Spindle speed 8000min ⁻¹
HM630/HM800S	19600N (4400lbf) [Opt]
HM800/HM1000S	19600N (4400lbf) [Opt]



SPINDLE POWER AND TORQUE DIAGRAM

HM Series

FANUC #40

10000min⁻¹ [37/26/22kW(50/35/30HP) MS]

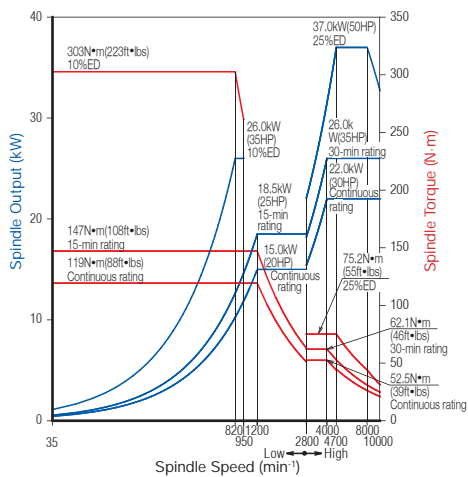

10000min ⁻¹	
Spindle motor	37/26/22kW(50/35/30HP) MS
HM400/40, HM500S/40	Standard

15000min⁻¹ [37/26/18.5kW(50/35/25HP) MS]

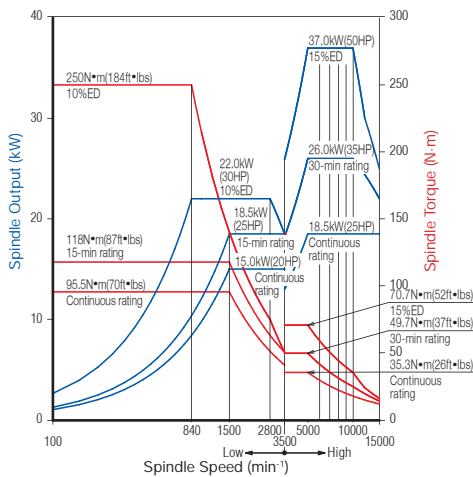

15000min ⁻¹	
Spindle motor	37/26/18.5kW(50/35/25HP) MS
HM400/40, HM500S/40	Option

20000min⁻¹ [37/26/18.5kW(50/35/25HP) MS]

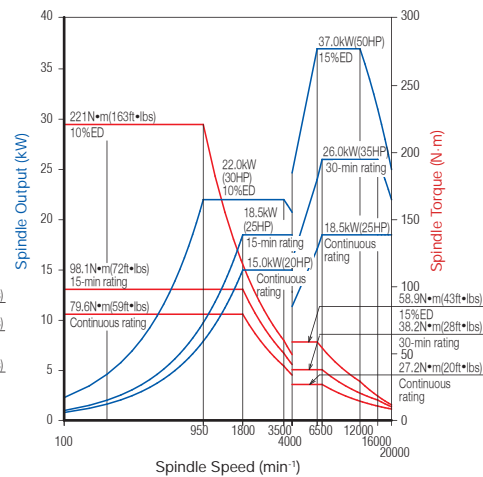

20000min ⁻¹	
Spindle motor	37/26/18.5kW(50/35/25HP) MS
HM400/40, HM 500S/40	Option

8000min⁻¹ [22 / 18.5kW(30/25HP) MS]

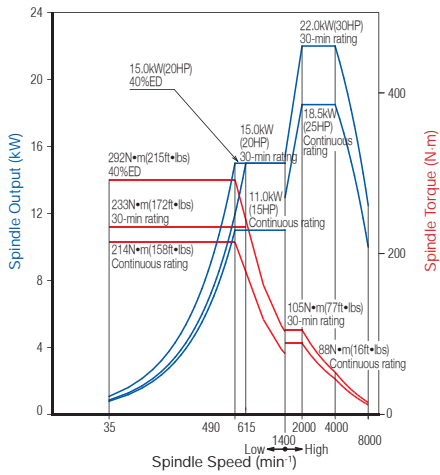

8000min ⁻¹	
Spindle motor	22/18.5kW(30/25HP) MS
HM400/50, HM500S/50	Option
HM5100/HM6000S	—
HM630/HM800S	—
HM800/HM1000S	—
HM1000/HM1250S	—

—: not available

8000min⁻¹ [22 / 18.5kW(30/25HP) Gear]

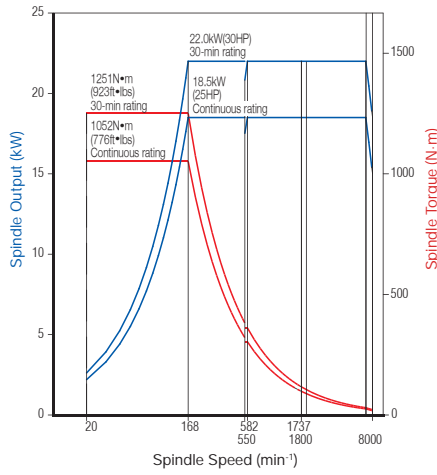

8000min ⁻¹	
Spindle motor	22/18.5kW(30/25HP) Gear
HM400/50, HM500S/50	—
HM5100/HM6000S	—
HM630/HM800S	Option
HM800/HM1000S	Option
HM1000/HM1250S	—

—: not available

8000min⁻¹ [30 / 25kW(40/34HP) MS]

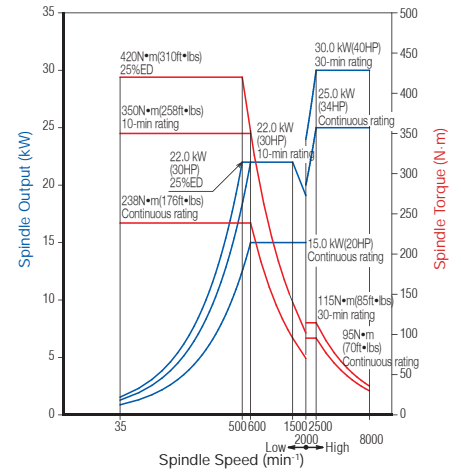

8000min ⁻¹	
Spindle motor	30/25kW(40/34HP) MS
HM400/50, HM500S/50	—
HM5100/HM6000S	—
HM630/HM800S	—
HM800/HM1000S	Standard
HM1000/HM1250S	—

—: not available

8000min⁻¹ [37 / 30kW(50/40HP) MS]

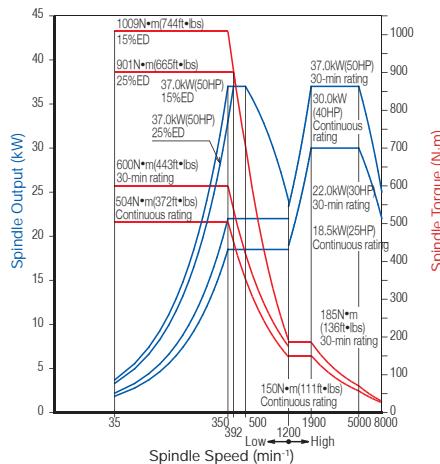

8000min ⁻¹	
Spindle motor	37/30kW(50/40HP) MS
HM400/50, HM500S/50	—
HM5100/HM6000S	—
HM630/HM800S	—
HM800/HM1000S	—
HM1000/HM1250S	Option

—: not available

12000min⁻¹ [30 / 25kW(40/34HP) MS]

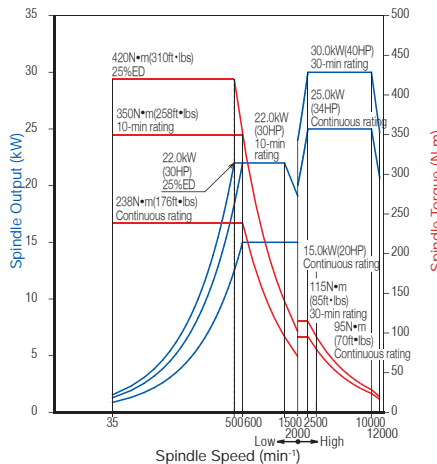

12000min ⁻¹	
Spindle motor	30/25kW(40/34HP) MS
HM400/50, HM500S/50	Standard
HM5100/HM6000S	—
HM630/HM800S	—
HM800/HM1000S	Option
HM1000/HM1250S	Standard

12000min⁻¹ [45/30/26kW(60/40/35HP) MS]

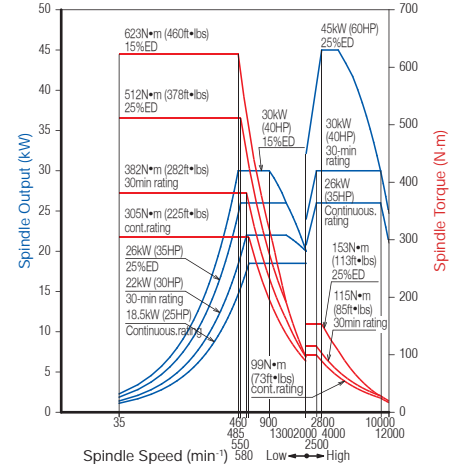

12000min ⁻¹	
Spindle motor	45/30/26kW(60/40/35HP) MS
HM400/50, HM500S/50	—
HM5100/HM6000S	Standard
HM630/HM800S	Standard
HM800/HM1000S	Option
HM1000/HM1250S	Option

—: not available

Table Indexing, Rotating Time and Accuracy

For the IT (Index Table) specification, the table index accuracy of 2.5 seconds is guaranteed by using the large-diameter curvic couplings.

For the BRT (Built-in Rotary Table) specification, that has a rotary encoder as standard equipment, the table index accuracy of 2.5 seconds is guaranteed.

Machine model	Type of table	Index and rotation time (per 90°)
HM400/HM500S	BRT	0.5 sec
	IT[Opt]	1.9 sec
HM5100/HM6000S	BRT	0.5 sec
	IT[Opt]	1.7sec
HM630/HM800S	BRT	0.6 sec
	IT[Opt]	1.7 sec
HM800	IT	4.5 sec
HM1000S	IT	5.5 sec
HM800/HM1000S	BRT[Opt]	1.2 sec
	IT	5.0 sec
HM1000/HM1250S	IT	5.0 sec
	BRT[Opt]	1.8 sec

IT: Index table BRT: Built-in-Rotary Table



Structure of BRT

Drive with new method
(HM400/HM500S, HM5100/HM6000S, HM630/HM800S)

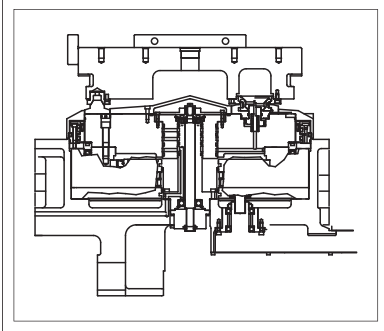

Worm and worm wheel drive
(HM800/HM1000S, HM1000/HM1250S)

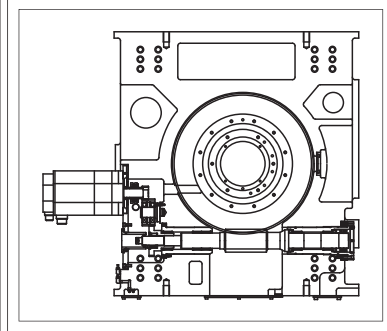

M400/HM500S, HM5100/HM6000S, and HM630/HM800S models incorporate a newly designed table with a highly rigid reduction gear in place of a conventional worm shaft and wheel. This gear has minimal backlash, holds up to impact, and performs table indexing accurately at higher speeds. HM800/HM1000S and HM1000/HM1250S models use large-diameter bearings backing OKK's continuous improvements on rigidity.

Direct Turn APC (Automatic Pallet Changer)

The HM Series exploits the direct-turn APC unit consisting of only a pallet lift and turning mechanism. Fewer parts mean less downtime. HM1000 and HM1250S a table load of 5000kg (11000 lbs) is available as an option. All APC units have been built with expansion in mind whether it's a pallet pool or transfer system, flexibly supporting a variety of machining environments.

Machine model	Pallet changing time*1	Max. loadable weight on pallet kg (lb)*2
HM400	9.5 sec	450 (992)
HM500S	9.5 sec	450 (992)
HM5100	10.5 sec	800 (1764)
HM6000S	10.5 sec	700 (1543)
HM630	15 sec	1300 (2600)
HM800S	15 sec	1200 (2900)
HM800	19 sec	2000 (4400)
HM1000S	21 sec	2500 (5500)
HM1000	32 sec/43 sec[Opt]	3000 (6600)/5000 (11000) [Opt]
HM1250S	35 sec/43 sec[Opt]	3000 (6600)/5000 (11000) [Opt]

*1: JIS regulation time *2: Uniformly distributed loading



HM400 / HM500S



HM5100/HM6000S

High Precision Structure

Lubrication oil cooler unit



All models of HM-series use core cooling ball screws on the X, Y and Z axes. Circulation of cooling oil through the ball screws, around ball screw support housings and motor mounting surfaces reduces the thermal displacement and maintains accuracy during long machining time.

Core cooling ball screws and Double anchor pre-tension system

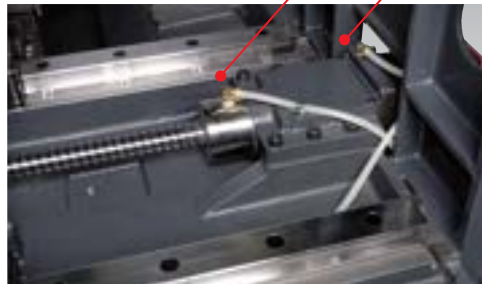
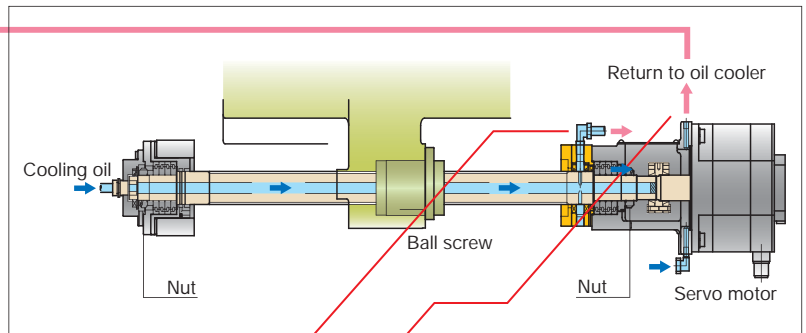

The double-anchoring method limits elongation of the ball screws and improves the minute-feed characteristics and the lowers lost-motion characteristics. Accuracy in round cutting has also been improved largely.

Double Anchored Core Cooling Ball Screw, and Linear Roller Guides

HM400/HM500S



HM5100/HM6000S



HM1000/HM1250S



Tool Magazine for BT40

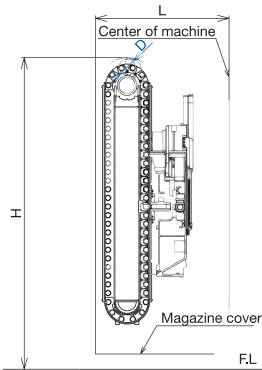

40, 60, 80-tool capacity magazine

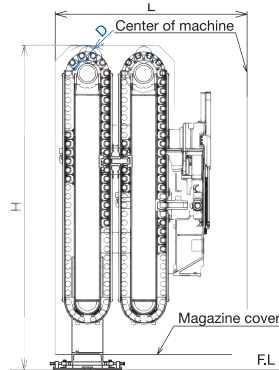

120, 156-tool capacity magazine

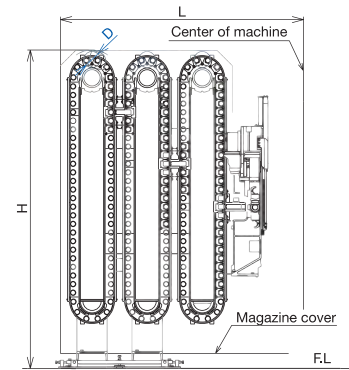

178, 232-tool capacity magazine

Machine Model	HM400/40, HM500S/40		
Tool storage capacity ^{*1}	L mm (in)	H mm (in)	D mm (in) ^{*2}
40tools [Std]	1315 (51.77)	2480 (97.64)	ø160 (6.30)
60tools [Opt]		3065 (120.67)	
80tools [Opt]		3915 (154.13)	
120tools [Opt]	1860 (73.23)	3150 (124.02)	
156tools [Opt]	2405 (94.69)	3875 (152.56)	
178tools [Opt]		3150 (124.02)	
232tools [Opt]		3875 (152.56)	

*1: The number of tool storage capacity refers a total number including the tool installed in the spindle i.e. subtract one from the above for the actual number of storage capacity.

*2: D shows the max. diameter of tool without tool in adjacent pot. It is ø82mm (3.23") when tool is in adjacent pot.



40-tool capacity [Std]



60-tool x 2magazines=120-tool capacity [Opt]

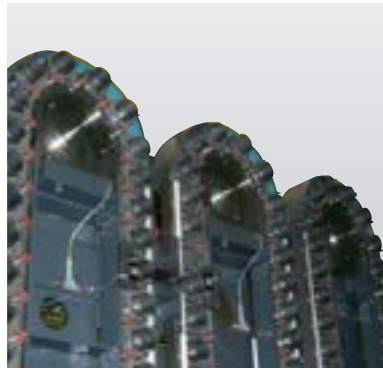

80-tool x 3magazines=232-tool capacity [Opt]



Matrix magazine [Opt]

Restriction of tools

Machine model	Max. tool length	Max. diameter with tool in adjacent pot	Max. diameter without in adjacent pot	Max.weight of tool	Moment load
	mm (in)	mm (in)	mm (in)	kg (lb)	N·m (ft·lbs)
HM400/40, HM500S/40	400 (15.75) ^{*1}	ø82 (3.23) ^{*1}	ø160 (6.30) ^{*1}	12 (26.5) ^{*2}	9.8 (7.2)

*1: It is loadable under the restriction. (Refer to P34)

*2: required slow ATC speed.

Tool Magazine for BT50

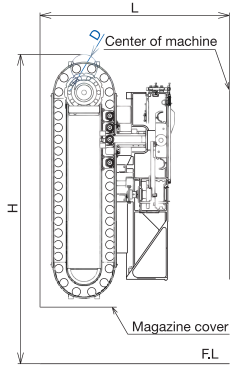

40, 60-tool capacity magazine

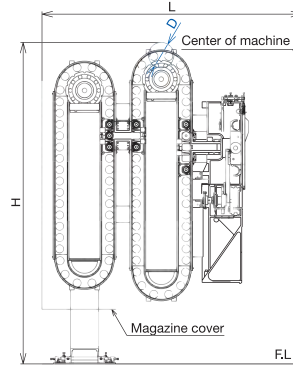

80, 116-tool capacity magazine

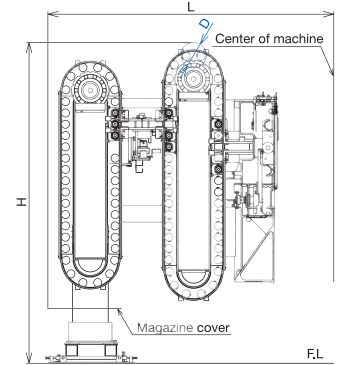

120, 176-tool capacity magazine

Machine Model	HM400/50, HM500S/50			HM5100/HM6000S			HM630/HM800S			HM800/HM1000S			HM1000/HM1250S		
Tool storage capacity ¹	L mm(in)	H mm(in)	D mm(in) ²	L mm(in)	H mm(in)	D mm(in) ²	L mm(in)	H mm(in)	D mm(in) ²	L mm(in)	H mm(in)	D mm(in) ²	L mm(in)	H mm(in)	D mm(in) ²
40 tools [Std] ¹	1715 (67.52)	2970 (116.93)	ø250 (9.84)	1990(78.35)	2915 (114.76)	ø300 (11.81)	2005 (79)	3170 (124.8)	ø270 (10.63)	2180 (85.8)	3375(132.9)	ø270 (10.63)	2330 (91.7)	3650 (143.7)	ø270 (10.63)
60 tools [Opt] ³		4170 (164.17)		4115 (162.01)	4115 (162.01)		4370 (172.1)	4335 (170.7)		4335 (170.7)	4610 (181.5)				
80 tools [Opt]	2530 (99.61)	3210 (126.38)	ø250 (9.84)	2835(111.61)	3155 (124.21)	ø300 (11.81)	2820 (111.1)	3410 (134.3)	ø270 (10.63)	2995 (117.9)	3615(142.3)	ø270 (10.63)	3160 (124.4)	3890 (153.2)	ø270 (10.63)
116 tools [Opt]		4170 (164.17)		4115 (162.01)	4370 (172.1)		4335 (170.7)	4610 (181.5)							
120 tools [Opt]	2850 (112.20)	3210 (126.38)		3150(124.02)	3155 (124.21)		3120 (122.8)	3410 (134.3)		3295 (129.7)	3615(142.3)		3445 (135.6)	3890 (153.2)	
176 tools [Opt]		4170 (164.17)		4115 (162.01)		4370 (172.1)	4335 (170.7)	4610 (181.5)							

*1: The number of tool storage capacity refers a total number including the tool installed in the spindle i.e. subtract one from the above for the actual number of storage capacity. (40, 60-tool magazine)

*2: D shows the maximum diameter of tool when without tool in adjacent pot. It is ø115mm (4.53") when tool is in adjacent pot.

*3: Standard for HM5100/HM6000S.



60-tool capacity [Opt]



40-tool x 2 magazines=80-tool capacity [Opt]



60-tool x 4 magazines=236-tool capacity [Opt]



Matrix magazine [Opt]

Restriction of tools

Machine model	Max. tool length ¹		Max. diameter with tool in adjacent pot ¹	Max. diameter without in adjacent pots ¹	Max. weight of tool	Moment load
	Standard mm (in)	Option mm (in)	Standard mm (in)	mm (in)	kg (lb)	N-m (ft-lbs)
HM400/50, HM500S/50	400 (15.75)	—	ø115 (4.53)	ø250 (9.84)	25 (55) ²	29.4 (21.7)
HM5100/HM6000S	600 (23.62)	—	ø115 (4.53)	ø300 (11.81)	30 (66) ²	29.4 (21.7)
HM630/HM800S	500 (19.69)	600 (23.62)	ø115 (4.53)	ø270 (10.63)	25 (55) ³	29.4 (21.7)
HM800/HM1000S	500 (19.69)	600 (23.62)	ø115 (4.53)	ø270 (10.63)	25 (55) ³	29.4 (21.7)
HM1000/HM1250S	600 (23.62)	—	ø115 (4.53)	ø270 (10.63)	25 (55)	29.4 (21.7)

* The maximum work diameter is to be smaller when 600mm (23.62") tool length is used. (HM630/800S)

—: not available

* When three or more multiple magazines, 600mm (23.62") length tools are usable in the first and second magazines.

In the 3rd or the following magazines, the maximum tool length shall be limited to 500mm (19.69").

*1: It is loadable under the restriction. (Refer to P34, P36, P38, P40, P42)

*2: Required slow ATC speed.

*3: 30kg (66lbs) for the gear head spindle



Matrix magazine [Opt]

Use of the OKK's proven and original high-speed synchronous tool changer (OKK patented) provides the steady tool change and excellent durability. In order to realize the smooth tool change operation, the standard specification includes the variable ATC function and, when the ATC handles the tool such as the heavy tool and the large-diameter tool, the ATC turning speed slows down automatically if the slow turning is selected at the time of tool registration.

BT40

Max.time the farthest position to waiting position of magazine			
60-tool magazine base		80-tool magazine base	
60-tool	13 sec	80-tool	16.5 sec
120-tool	26.7 sec	156-tool	31.3 sec
178-tool	36.2 sec	232-tool	47.1 sec

Tool change time (cut to cut)	
Machine model	Standard
HM400/40, HM500S/40	3.3 sec



HM400/HM500S

BT50

Max.time the farthest position to waiting position of magazine			
40-tool magazine base		60-tool magazine base	
40-tool	10.0 sec	60-tool	13.5 sec
80-tool	30.3 sec	116-tool	37.3 sec
120-tool	33.2 sec	176-tool	40.2 sec
160-tool	34.2 sec	236-tool	41.2 sec

Tool change time (cut to cut)		
Machine model	Standard	Gear-drive spindle
HM400/50, HM500S/50	4.2 sec	—
HM5100/HM6000S	3.6 sec	—
HM630/HM800S	4.4 sec	5.0 sec
HM800/HM1000S	5.8 sec	6.0 sec
HM1000/HM1250S	6.2 sec	—

—: not available

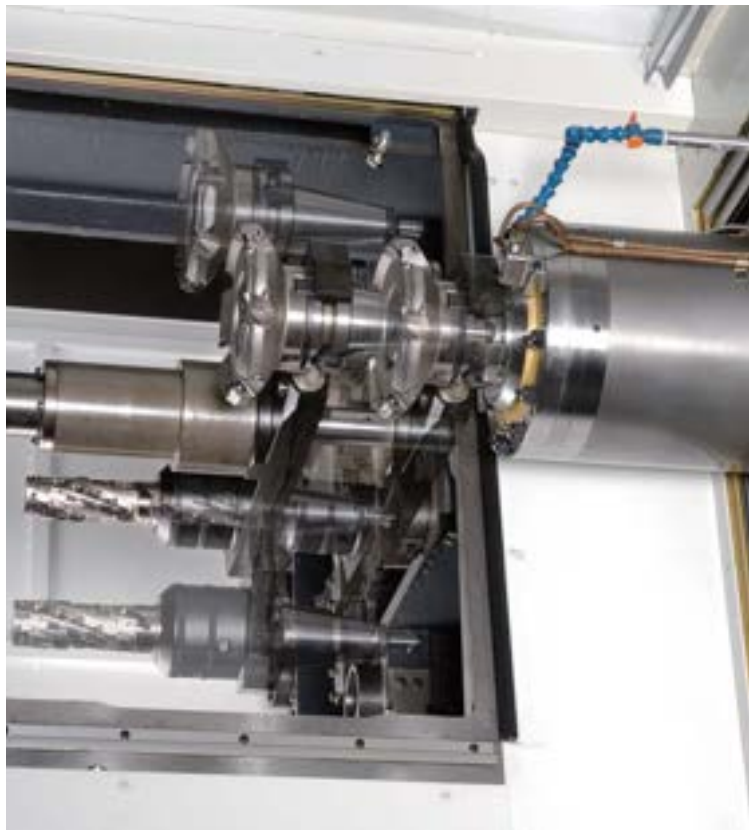

HM630/HM800S

* 600mm (23.62") tool length specification is standard only for HM1000/HM1250S. The other models are option.



Cutting data	
Machine model	HM800
Tool	ø100mm (3.94") Face milling
Material	FC300 (Cast iron)
Spindle speed	800 min ⁻¹
Feed rate	800mm/min (31.50 in/min)
Depth of cut	3.0mm (0.12")
Width of cut	90.0mm (3.54")



Linear roller guide

The machines use an intense linear roller guide system that is simply built to last, through all high feed rates, rapid accelerations and performs superbly in high-load machining.

Ball screw with pre-lubricated seals

In order to reduce the environmental burdens, the grease lubrication method is used for lubricating the ball screws / feed guides.



Ball screw with pre-lubricated seals

Pallet positioning and clamping

Use of taper cones ensures high accuracy in repeated positioning of the pallets. Flatness of the pallet is secured accurately by means of the multi-clamp method. (HM400/HM500S use center clamp method.)



Multi-clamp method

Soft scale II m [Spindle thermal displacement compensation function]

Thermal displacement of the spindle can be a cause for fluctuating machining accuracy. The soft scale II m reduces thermal displacement of the spindle and provides stable machining accuracy. The soft scale II m constantly monitors a rotating status of the spindle and temperature of the spindle and the machine body in order to compensate automatically the thermal displacement according to changes in machine movement and based on the accumulated OKK's original data.

Spindle thermal displacement (HM630 actual data example)

Y axis

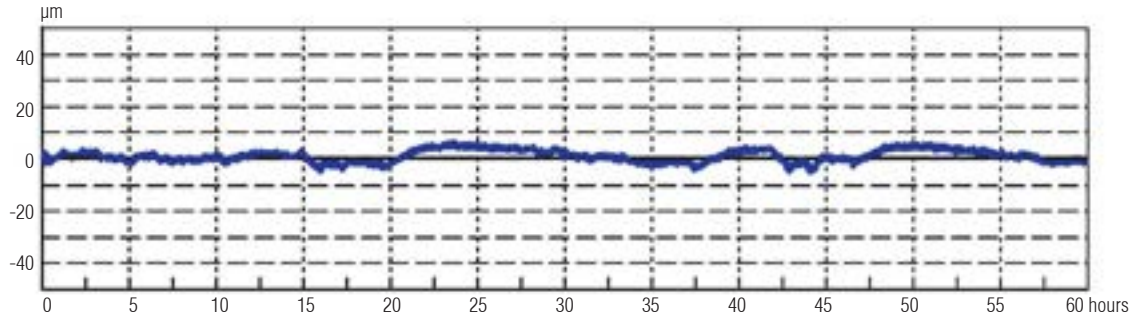

Z axis

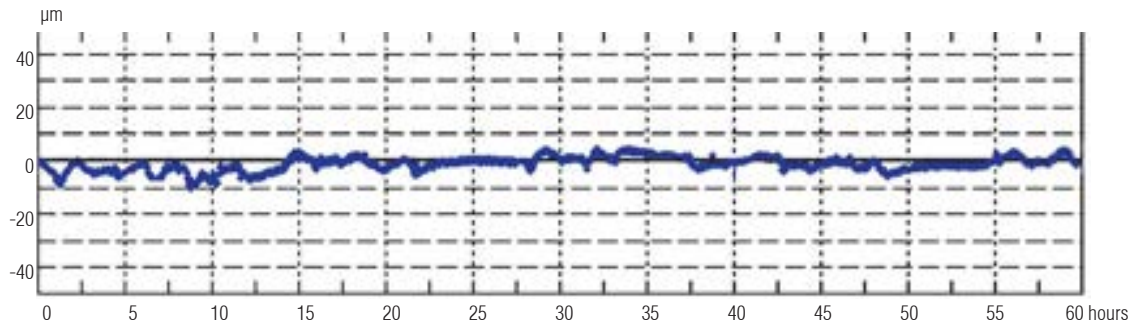

Cutting data	
Spindle speed	0~12000 min ⁻¹
Room temperature	21°C (±1°C)
Total running hours	60 hours included warming up time

* Due consideration should be taken for the machine installation status, environmental temperature and operating condition. The data here may not be obtained due to these conditions.

Accuracy of roundness

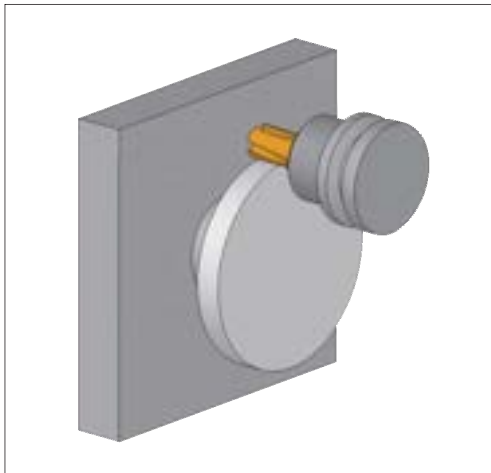

Roundness	Tolerance	Actual data example
HM400/HM500S	15µm(0.00059")	3.6µm(0.00014")
HM5100/HM6000S	15µm(0.00059")	3.8µm(0.00015")
HM630/HM800S	15µm(0.00059")	3.3µm(0.00013")
HM800/HM1000S	15µm(0.00059")	4.5µm(0.00018")
HM1000/HM1250S	15µm(0.00059")	5.0µm(0.00020")

Data condition	
Material	Aluminum
Cutting dia	250mm (9.85")
Feed rate	F500mm/min (19.7in/min)

Notes:

1. The data show example which obtained in short run. It may differ from data obtained in continuous run.
2. The data were obtained under OKK's test cutting conditions. The data may differ due to conditions of cutting tools, fixtures, cutting speed and room temperature.
3. The above accuracy are subject to machine installed according to OKK specifications and constant temperature environment. Accuracy are based on OKK inspection standard.

Cutting data

Face milling

Material: S45C

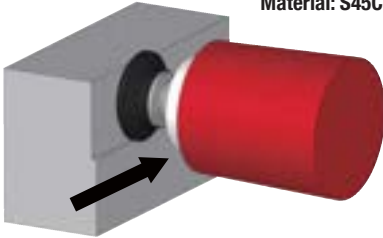

Face milling

Material: S45C

	HM400/40, HM500S/40 ø100mm (4") x6 - tooth	HM5100/HM6000S ø125mm (4.9") x6 - tooth	HM630/HM800S HM800/HM1000S ø125mm (4.9") x6 - tooth	HM1000/HM1250S ø125mm (4.9") x6 - tooth
Spindle speed	1000min ⁻¹	600min ⁻¹	300 min ⁻¹	300 min ⁻¹
Cutting width	80mm (3.15")	100mm (3.94")	100 mm (3.94")	100 mm (3.94")
Cutting depth	5mm (0.20")	5mm (0.20")	6 mm (0.24")	6 mm (0.24")
Feed rate	800mm/min (31ipm)	1200mm/min (47ipm)	600 mm/min (23.6 in/min)	1000 mm/min (39.4 in/min)
Cutting amount	320cm ³ /min (19.5in ³ /min)	600cm ³ /min (36.6 in ³ /min)	360 cm ³ /min (22 in ³ /min)	600 cm ³ /min (36.6 in ³ /min)

End milling on side

Material: S45C

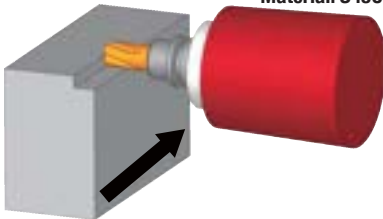

End milling on side

Material: S45C

	HM400/40, HM500S/40 ø32mm (1.26") x6 - tooth	HM5100/HM6000S ø50mm (1.97") x6 - tooth	HM630/HM800S HM800/HM1000S ø50mm (1.97") x6-tooth Roughing end mill	HM1000/HM1250S ø50mm (1.97") x6-tooth Roughing end mill
Spindle speed	250 min ⁻¹	160 min ⁻¹	160 min ⁻¹	160 min ⁻¹
Cutting width	32 mm (1.26")	20 mm (0.79")	25 mm (0.98")	15 mm (0.59")
Cutting depth	16 mm (0.63")	40 mm (1.57")	40 mm (1.57")	50 mm (1.97")
Feed rate	200 mm/min (7.87 in/min)	180 mm/min (7.09 in/min)	160 mm/min (6.3 in/min)	300 mm (11.8 in/min)
Cutting amount	102 cm ³ /min (6.2 in ³ /min)	144 cm ³ /min (8.8 in ³ /min)	160 cm ³ /min (9.8 in ³ /min)	225 cm ³ /min (13.7 in ³ /min)

High feed rate machining

Material: S50C

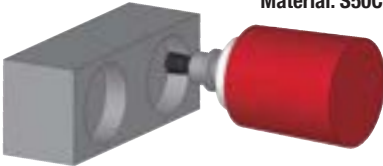

High feed rate machining

Material: S50C

	HM630/HM800S, HM800/HM1000S ø50mm (1.97") High feed rate cutter
Spindle speed	1400 min ⁻¹
Cutting width	40 mm (1.57")
Cutting depth/round	0.5 mm (0.02")
Feed rate	7000 mm/min (276 in/min)

Sample work pieces



Easy Operation

By the design of swivel operation panel and considerate splashguard of accessibility, the accessibility to spindle and pallet is significantly improved.



HM400 / HM500S



HM5100 / HM6000S



HM800 / HM1000S

Easy loading and unloading

Front door of the APC opens wide so that the work loading/unloading and setup operations can be carried out easily.



HM1000 / HM1250S



HM5100 / HM6000S

Easy Tool Loading and Unloading in Tool Magazine

1 Magazine interruption function [Std]

During automatic operation, the tool loading and unloading operation in the tool magazine can be executed.

2 Operation panel [Opt]

Through a simple operation, a tool corresponding to a designated tool number is called up to the setup position inside the magazine.

3 Foot-operated switch for removing a tool [Opt*]

The foot-operated switch eases removal of a tool from a magazine pot.

*: Standard for Dual-contact holder



Operation Stand [Opt]



The operation stand is supplied optionally as needed.

*: Standard for HM1000/HM1250S

Photo is an example of operation stand.

Maintenance

Daily maintenance equipment is easily performed at the back and one side of machine.

HM400/50, HM500S/50



HM5100 / HM6000S

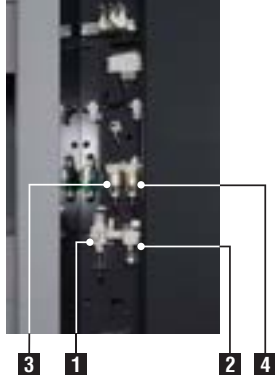

HM800/HM1000S

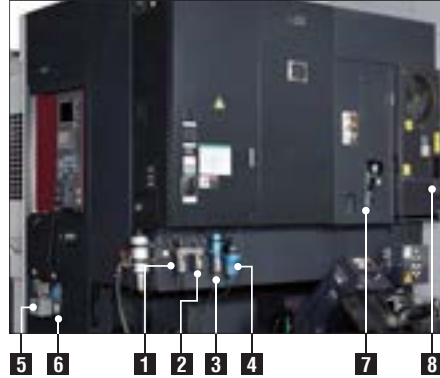

Daily maintenance equipment

No.	Name of equipment	No.	Name of equipment
1	Air regulator	5	Manual oil supply for magazine
2	Air lubricator	6	Spindle oil-air unit
3	Air dryer	7	Hydraulic unit
4	Oil -in-air removing unit	8	Oil temperature control unit for Spindle and screws



Automatic lubrication unit for magazine and ATC part [Opt]



Automatic grease lubrication unit for linear guides and ball screws [Opt]

Eco friendly

ECO sleep function [Standard]

If the machine remains idle longer than the specified time period, the machine's present mode is switched to a power-saving mode to reduce wasteful consumption of power, air and so on. When the power-saving mode is active, the equipment such as servos and chip conveyors are turned off. It is cancelled automatically when the setup operation is completed i.e. when the doors are closed.

Hydraulic free ATC unit *1

OKK has an added advantage of eco-friendly reliability with our use of a hydraulic free, mechanical cam driven ATC unit.

LED lamps

The machine incorporates LED lamps due to their low heat generation and power consumption savings. Furthermore, the LED lamps have a long life to save replacement money and maintenance.

Turning off lights inside the machine [Opt]

When the machine is not operated for a certain period of time, lights inside the machine are turned off automatically.

*1: Except for HM400/40, HM500S/40 and HM5100/HM6000S



LED lamp work light

Easy return of ATC and APC

Tools and pallets can be returned easily to origin position in accordance with monitor, even if stopped at half way of ATC and APC.



Stopped at half way of ATC



Guidance display for ATC



ATC arm returned to origin position



Stopped at the half way of APC



Guidance display for APC



Pallet returned to origin position

STANDARD AND OPTION LIST

HM Series

Standard and optional Accessories

Standard Option Not available

Item			HM400/40	HM400/50	HM5100	HM630	HM800	HM1000
			HM500S/40	HM500S/50	HM6000S	HM800S	HM1000S	HM1250S
Controller	FANUC	FAi						
		F31i						
		F31i-B5	Essential for the 5-axis simultaneous control					
Spindle taper and pull stud	Taper	BT40						
		BT50						
	Two faces contact holder	HSK-A63						
		HSK-A100						
	Pull stud	BT type						
		OKK90°						
MASI								
Maximum spindle speed	BT40	MS	1000min ⁻¹		37/26/22kW (50/35/30HP)			
			1500min ⁻¹		37/26/18.5kW (50/35/25HP)			
			2000min ⁻¹		37/26/18.5kW (50/35/25HP)			
	BT50	MS	8000min ⁻¹		22/18.5kW (30/25HP)			
					30/25kW (40/34HP)			
		Gear			37/30kW (50/40HP)			
MS	12000min ⁻¹			22/18.5kW (30/25HP)				
				30/25kW (40/34HP)				
Table/Axis	Table	IT (Index Table)			Least Index 1°			
		BRT (Built-in rotary table)			Least Index 0.001°			Least Index 0.001°
	Rapid feed rate 75m/min (2953ipm)					X-axis-Z-axis only		
	Addition of controlled axis			*1	*1	*1	*1	*1
Magazine	BT40 HSK-A63	40MG			40MG×1			
		60MG			60MG×1			
		80MG			80MG×1			
		120MG			62MG×2			
		156MG			80MG×2			
		178MG			62MG×3			
		232MG			80MG×3			
	200MG/300MG/400MG			Matrix magazine				
	BT50 HSK-A100	40MG			40MG×1			
		60MG			60MG×1			
		80MG			44MG+40MG	*2	*2	*2
		116MG			60MG×2	*2	*2	*2
		120MG			44MG+40MG×2			
		160MG			44MG+40MG×3			
176MG				60MG×3	*2	*2	*2	
236MG			60MG×4	*2	*2	*2		
200MG/300MG/400MG			Matrix magazine					
Magazine Interruption function								
Magazine operation panel								
Tool holder remove by foot pedal					Standard for BT50/HSK Dual-contact holder			
For Automatic pallet handler and Pallet	APC	2-pallet APC						
		Multiple APC			6-pallet APC			
		Separate setup station for the multiple APC ^{Note 1}			8-pallet APC			
	Pallet	Tapped type Pallet			25-M16 screw	25-M16 screw	24-M16 screw	24-M16 screw
T-Slot type Pallet								
Additional Pallet								
For Coolant and Chip conveyor	Coolant tank	Standard Coolant tank						
		Lift up chip conveyor			Hinged type/Scraper type/with Draum filter			
	Chip ejection	Coil conveyor						
		Chip flow coolant			Bed left and right			
		Spindrecoolant nozle			Bed left and right			
	Collant	Ceiling Shower						
		Coolant shower gun						
		Air blow and oil mist						
		Coolant through spindle			2MPa (290psi) /7MPa (1015psi)			
		Air through spindle						
Oil hole								
Oil skimmer								
Mist collector								
For accuracy	Dubble anchor pretension ball screw				With core cooling ball screw			
	Lubrication oil cooler unit							
	Linear scale feed back				XY-axis or XYZ-axis			
	Coolant cooler unit							
Other accessories	Signal tower lamp				Tow lamp without buzzer			
	Working light				LED light			
	Workpiece automatic measurement	Touch sensor T0			Manual measurement			
		Touch sensor T1-A			Workpiece automatic measurement			
	Tool length measurement and break detection	Touch sensor T1-B			Workpiece automatic measurement/ Tool length automatic measurement/ Tool break detection			
		Touch sensor T1-C			Tool length automatic measurement/Tool break detection			
	Tool break detection	Tool break detection in magazine*4			Contact type or laser type			
	Automatic grease lubrication unit				XYZ -axis/ball screw			
	Automatic oil lubrication unit for MG and ATC part							
	Foundation parts for machine anchoring				Bond anchoring method			
Rotary window				at operation door				

MG: Tool magazine unit

Note 1: The separate setup station for the multiple APC is regarded as the standard specification when the multiple pallet specification is selected. (Except for HM400/500S and HM5100/HM6000S)

*1: The controller needs to be changed when the 5-axis simultaneous control is selected.

*2: It is not available for the HSK-A100.

*3: Twenty-four M20s are used for HM1250S.

*4: It is available only for the FANUC controller.

High pressure coolant through spindle [Opt]

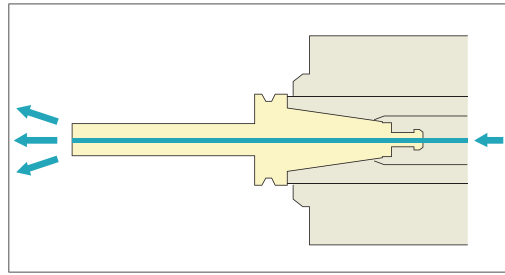
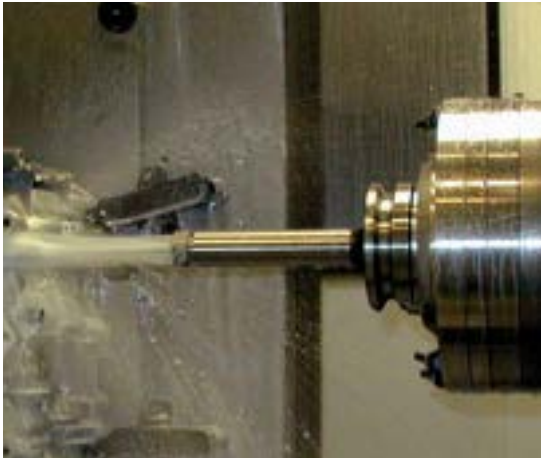

High pressure coolant unit

High pressure coolant is supplied to the tip of a cutting tool through the center hole of spindle and the cutting tool. It is very efficient for chip removal, cooling the cutting point and extending the life of cutting tools. Air supply through the spindle is also available by switching a valve. [Another Opt]



Thickener bag filter

Discharge pressure Mpa (psi)		2.0 (290)	7.0 (1,015)
	Discharge volume L/min (gpm)	50Hz	60Hz
		36 (9.5)	21 (5.5)
		35 (9.2)	30 (7.9)

Notes :
 *Discharge values indicated are at the outlet of pump.
 *Actual discharge volumes from the tool are different due to the hole-diameter of cutter tools.

Coolant shower gun [Opt]



Air blow nozzle [Opt]



Automatic grease lubrication unit for linear guides and ball screws [Opt] *1



Automatic lubrication unit for magazine and ATC part [Opt]*2



Mist collector [Opt]*3



Oil mist & Air blow [Opt]



Mist collector suctions mist from the splash guards and is recommended when high-pressure coolant is used.

*1: Only for HM630/HM800S, it is regarded as the optional specification. *2: Standard for HM5100/HM6000S, HM1000/HM1250S.
 *3: We can provide the mounting holes in the splash guard and a terminal block for wiring in the control panel for the customer to install the equipment that the customer prepares for themselves.

For more stable machining accuracy

Coolant cooler [Opt]

Oil temperature has a major factor in thermal displacement of machine. Coolant cooler suppresses rise of temperature generated during machining and achieves a stable machining accuracy. This option is recommendable for accurate machining. This option is also strongly recommended, when the oil-based coolant is used.

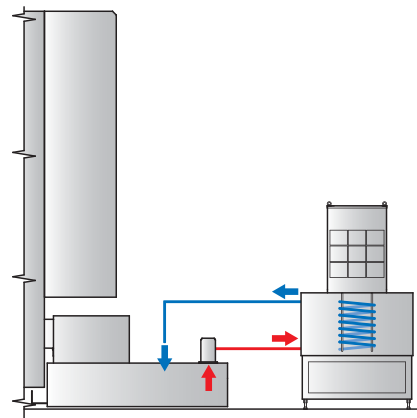

Spindle

Dual-contact [Opt]

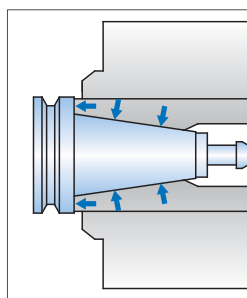

BT specification

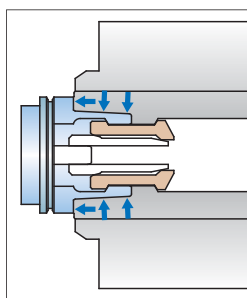

HSK specification



Spindle for Dual-contact holder of BT50



Dual-contact holder is loaded, no space between holder and spindle nose.



HSK-A63

Improvements in rigidity of tools have been achieved by contact faces of spindle-nose and tool holders flange. This has a great effect not only for heavy load machining but also high speed machining. (The performance is different due to the cutting tools and cutting conditions.)

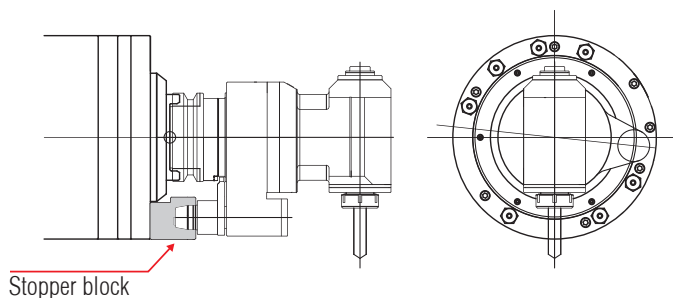

Stopper block [Opt]

- 1) For high speed spindle holder
- 2) For high speed spindle holder with coolant jacket
- 3) For angle head

Notes: Please inform OKK the brand name and model when you order this stopper block.

Type of pull stud

	7/24 taper No.40	7/24 taper No.50
OKK90°	Option	Standard
MASI	Standard	Option
MASI	Option	Option

OKK 90°

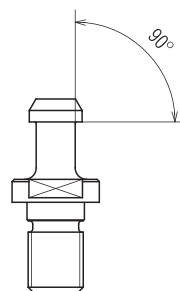

MASI

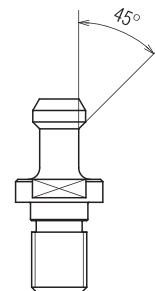



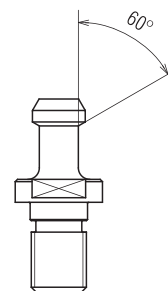









MASI



Lift up chip conveyor [Opt]

Suitable lift up chip conveyor according to type of chips

◎ Most suitable ○ Usable △ Usable under condition × Not usable - Not applicable

Type of chip conveyor		Hinge type		Scraper type		Magnet Scraper type		Scraper type with drum filter		Magnet scraper type with drum filter				
		Use	Not use	Use	Not use	Use	Not use	Use	Not use	Use	Not use			
Type of chips	Magnetizable chips	Steel	Short curl 	◎	◎	○	○	◎	◎	○	-	◎	-	
			Spiral 	◎	◎	△*2	△*2	△*2	△*2	×	-	×	-	
			Long 	◎	◎	×	×	×	×	×	-	×	-	
			Needle shape 	×	△*1	×	○	○*3	○	○	-	◎	-	
			Powder and small lump 	×	△*1	×	○	○*3	○	○	-	◎	-	
	Cast iron	Needle shape 	×	△*1	×	○	○*3	○	○	-	◎	-		
		Powder and small lump 	×	△*1	×	○	○*3	○	△*3	-	◎	-		
		Non-magnetizable chips	Aluminum	Short curl 	×	◎	△*4	○	-	-	◎	-	◎	-
				Spiral 	○	◎	○	○	-	-	△*5	-	△*5	-
				Long 	○	◎	○	○	-	-	△*5	-	△*5	-
Needle shape 	×			△*1	×	○	-	-	◎	-	◎	-		
Powder and small lump 	×			△*1	×	○	-	-	◎	-	◎	-		

*1 Minute chips can enter the conveyor through a gap on the hinged plate. So, inside of the conveyor needs frequent cleaning.

*2 Scraper can easily catch long chips. So, shortening the chips (for example by using the step feed) or removing such chips is required.

*3 When flow rate of the coolant is large, filters can be clogged with chips flowed out of the conveyor case. Therefore, combined use with a magnet plate is recommendable.

*4 When flow rate of the coolant is large, filters can be clogged with chips flowed out of the conveyor case. Therefore, filters require frequent cleaning.

*5 Scraper can easily catch long chips. Therefore, periodical removal of chips is needed. If they remain, a drum filter may be damaged.

Height of chip drop

Type of chip conveyor	Hinged type, Scraper type and Magnet scraper type	Scraper type with drum filter	Magnet scraper type with drum filter
HM400/HM500S	1020 mm (40.16")	1100 mm (43.31")	1100 mm (43.31")
HM5100/HM6000S	1020 mm (40.16")	1220 mm (48.03")	1220 mm (48.03")
HM630/HM800S	1020 mm (40.16")	1220 mm (48.03")	1220 mm (48.03")
HM800/HM1000S	1070mm (42.13")	1200mm (47.24")	1200mm (47.24")
HM1000/HM1250S	1070mm (42.13")	1200mm (47.24")	1200mm (47.24")

Photo is Scraper type.
Chip bucket is another option.
There are fixed type and swivel type.
Photo is fixed type chip bucket.

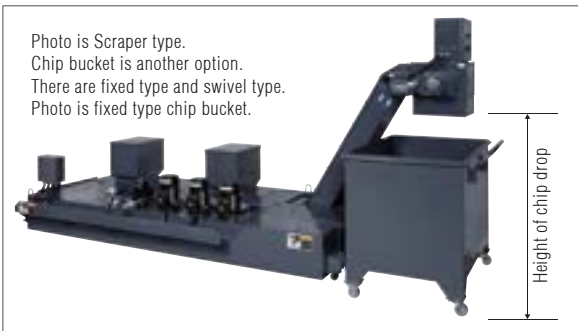

Magnet separator [Opt]



As an option for the lift-up chip conveyor, adding a magnet separator is possible for collecting powder and particle casting chips and preventing accumulation of chips inside tanks and clogging of devices such as pumps and filters.

Oil skimmer [Opt]



Oil skimmer collects contaminated oil from a coolant tank.

Rotary wiper [Opt]



Install on operators window

Automatic measurement and Tool breakage detection with OKK Touch sensor system [Opt]

Model of touch sensor system

Function	Description	System name	
Workpiece measurement and compensation	<ul style="list-style-type: none"> Load the touch sensor into the spindle. Automatic operations will bring the sensor or into contact with the workpiece. The workpiece coordinate system will be measured and the necessary compensation amount will be updated. Program instructions are issued according to the specified format. 	T1-A	T1-B
Tool length measurement	<ul style="list-style-type: none"> When a tool is commanded for tool length check, automatic operations will bring the tool in contact with the table mounted touch sensor. This operation will update the tool length offset for that tool. Measurement and compensation programs in accordance with the specified format are produced and executed. Applicable tools: Drills and taps 	T1-C	
Tool break detection	<ul style="list-style-type: none"> When a tool is commanded for broken tool check, automatic operations will bring the tool in contact with the table mounted touch sensor. If the tool tip does not make contact with the sensor at the designated offset length the tool is determined to be broken. This checking command can be put into the machining program at any point. Applicable tools: Drills and taps Details of the movement when tool break is detected depend on the specifications of the machine main unit. 		

*Adding the T0 software enables also the manual measurement. Please refer to "T0 software [Opt]" on the page 29.

Tool length measurement and Tool breakage detection

A tool in the tool magazine is called up to the spindle, and length of the tool is measured automatically and registered automatically as data of the tool length in respective offset number. After the tool is used in machining, the tool can be checked for breakage automatically. If the tool is detected as damaged, the machine issues an alarm and stops operating.



Tool breakage detection in tool magazine [Another Opt]

This function enables detecting tool breakage in the tool magazine while the machine is in the automatic operation.



* Non contact type sensor of laser system is also available.

Type of sensor



[OMP60] Renishaw

Use the optical signal transfer method. The signal receiver block is not needed since signals are sent and received by using infrared rays. The signal receiver module can be fitted on inside wall of splash guard.



[RMP60] Renishaw

Use the radio signal transfer method. It is suitable for the machines having long distance for signal transfer from the sensor to the receiver such as the large models and 5-axis machining centers.



[MP700] Renishaw

With a low and consistent trigger force in all sensing directions, the MP700 is ideal for complex and contoured part inspection.



[TC50] Blum

The multidirectional touch probe TC50 allows fast, precise and automatic determination of workpiece position and workpiece dimensions in machining centers.

Manual measurement with software of touch sensor system T0

A sensor is moved to the desired measuring position by operating a manual handle. The machine starts measuring automatically when the sensor comes into contact with a workpiece, and results of the measurement are reflected in the settings of desired work coordinate system and tool offset number through a simple operation.

The following centering and measuring are available.

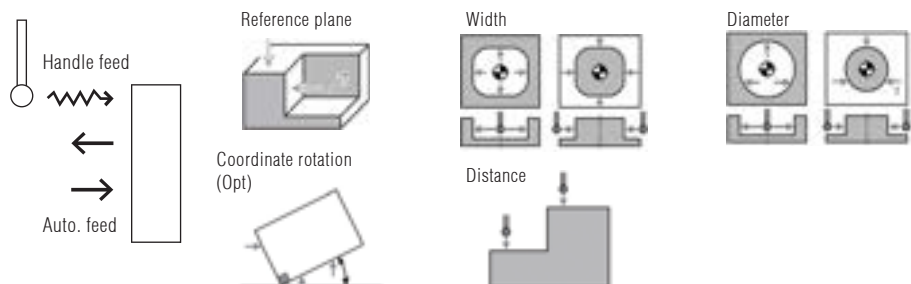

Hydraulic and compressed air supply ports for fixture [Opt]

Rotary joint on pallet system (Example 1)



Example of the use of 6-port rotary joint
(HM400/500S, HM5100/HM6000S)

Supply from above the fixture: Hydraulic or air pressure can be applied to the clamping device constantly so that the workpiece clamping device is prevented from getting loose during machining. However, height of the fixture is limited due to a rotary joint and its piping installed above the fixture.

The pallet-through method is simple and does not require a rotary joint and its piping above the fixture. However, the clamp/unclamp function is available only in the setup station.
(Hydraulic pressure and air pressure are not supplied after moving to the machining position.)

○ Available × Not available

	Rotary joint on pallet system	pallet through
HM400/HM500S	○	○
HM5100/HM6000S	○	○
HM630/HM800S	○	×
HM800/HM1000S	○	○
HM1000/HM1250S	○	○

Note1: The pallet-through system allows the clamping operations of the fixtures only in the work setup station.

Note2: Availability is depends on the supply source (hydraulic or air), pressure, number of ports and other specification.

Rotary joint on pallet system (Example 2)

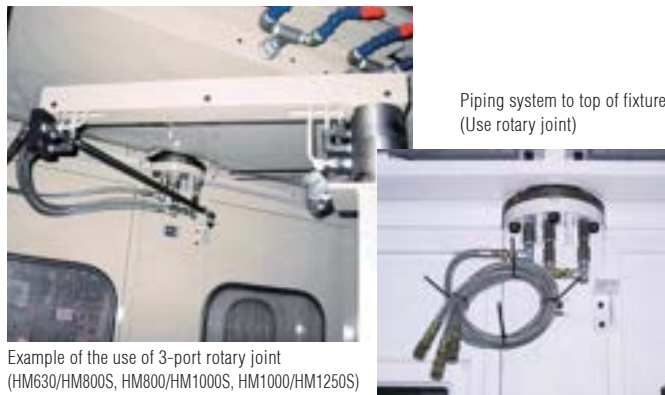

Piping system to top of fixture
(Use rotary joint)

Example of the use of 3-port rotary joint
(HM630/HM800S, HM800/HM1000S, HM1000/HM1250S)

Pallet through system (Use auto-coupler)



Photo with a fixture

Pallet through system (Use auto-coupler)

Fixture example

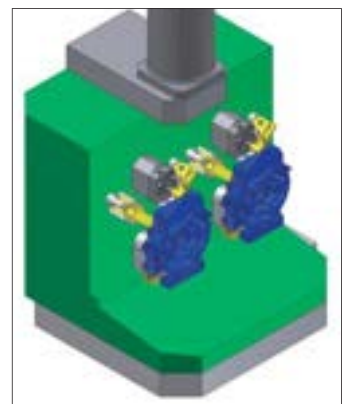
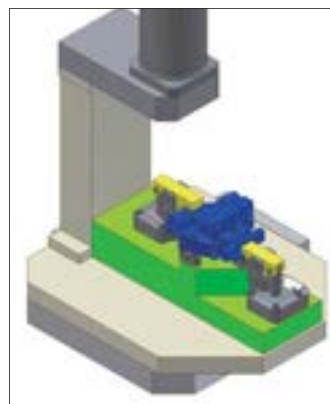
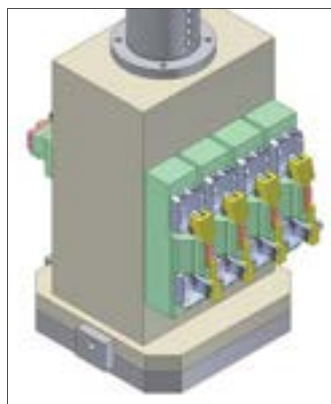

OPTIONAL PERIPHERAL EQUIPMENT

HM Series

Multiple-pallet APC [Opt]

HM400/HM500S



With standard safety cover
HM400/HM500S



With deluxe safety cover [Another opt]

[8APC]

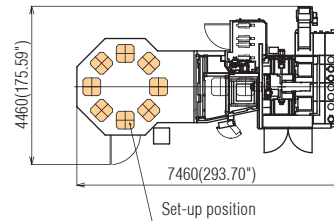

HM5100/HM6000S

[6-pallet with set-up station (pattern 1)]

[6-pallet with set-up station (pattern 2)]

[8-pallet with set-up station (pattern 1)]

[8-pallet with set-up station (pattern 2)]

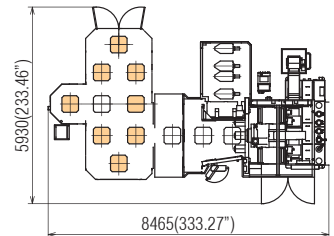
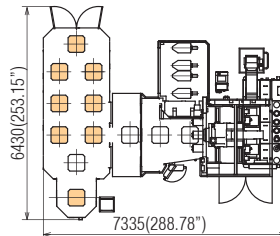
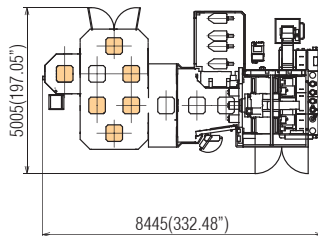
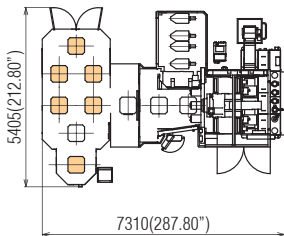

HM630/HM800S



HM630 6-pallet APC (Horizontal type)
Photo is taken without safety cover.

[6-pallet vertical type with set-up station]

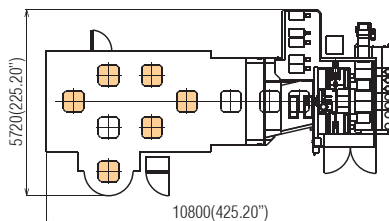

[6-pallet horizontal type with set-up station]

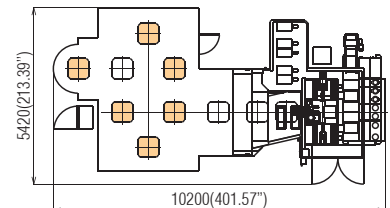

HM1000 6-pallet APC (Horizontal type)
Photo is taken without safety cover.

[8-pallet vertical type with set-up station]

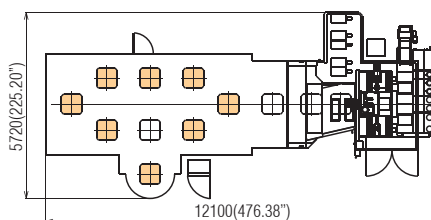

[8-pallet horizontal type with set-up station]

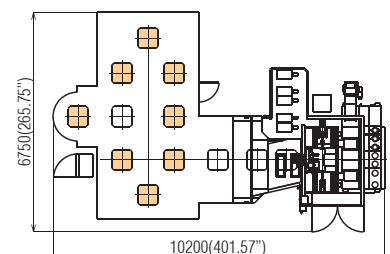

HM800/HM1000S

[6-pallet vertical type with set-up station]

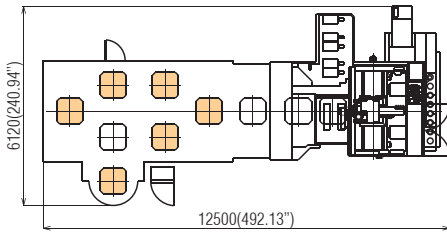

[6-pallet horizontal type with set-up station]

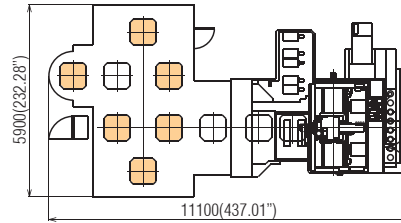

[8-pallet vertical type with set-up station]

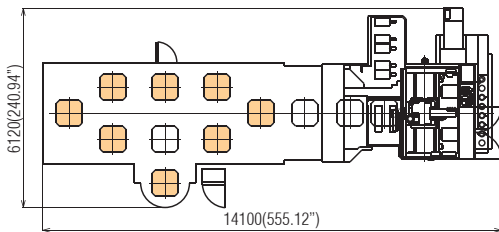

[8-pallet horizontal type with set-up station]

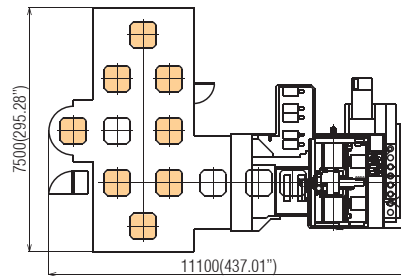

HM1000/HM1250S

[6-pallet horizontal type with set-up station]

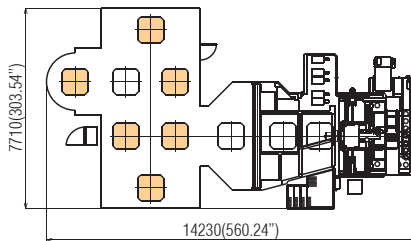

[6-pallet vertical type with set-up station]

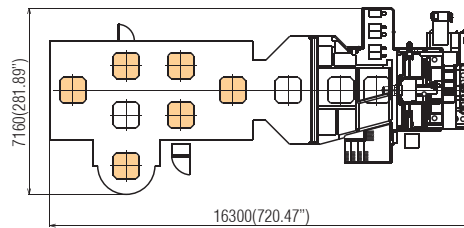

Auto restart function [Another Opt]

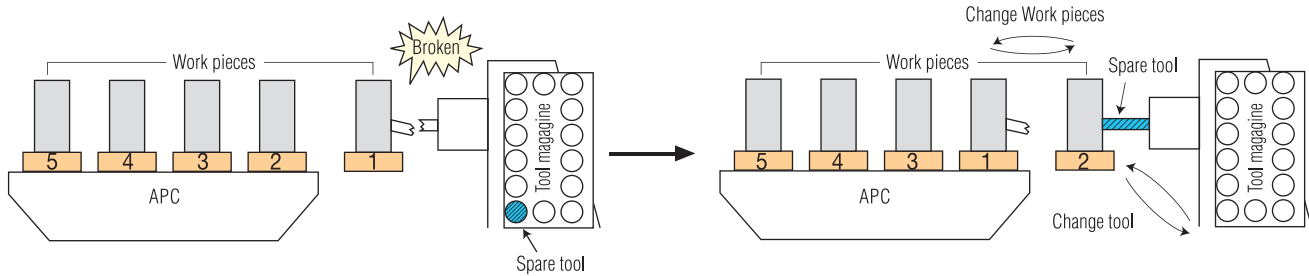

When a tool failure detected by a tool breakage detection system such as soft CCM, touch sensor system T1-C or others, automatic restart stops the machine and interrupts processing. The system will exchange the broken tool with an available spare tool then will either execute an APC or program end command.

OKK's exclusive control functions

Programming support functions

Program Editor [F31i-B]

Program editor allows you to edit programs stored in NC memory, from a data server (or hard disc) or memory card.



- Two programs can be displayed side by side.
- Characters in the program can be converted all at once. (Example: Changes F1000 to F1200.)
- Multiple-line data can be copied from other programs with ease.



- By switching the right-side screen for reference use, a list of M signals/G codes and information on tools in the magazine can be displayed.



- Programs can be copied or deleted and program names can be changed easily with the Program Editor.
- The Program Editor's multiple-file batch copy function enables to make a backup of the programs in the NC memory or hard disc easily with a memory card.

Setup support functions

Tool Support [F31i-B]

Now through a single set-up screen the tools number, description, schematic, and geometry are displayed.

You can also perform the tool change commands and measurement cycle at the same set-up screen.

Tool setup screen



Tool length compensation amount measurement screen



T0 software [Opt]

This screen enables the simple manual measurement using the touch sensor (option: T1-A or T1-B). You can move the sensor to the desired measuring point by handle mode then the machine starts the automatic measurement after the sensor contacts the workpiece. You can set the results of the measurement as the data for the desired workpiece coordinate system and tool offset number through the single key operation.

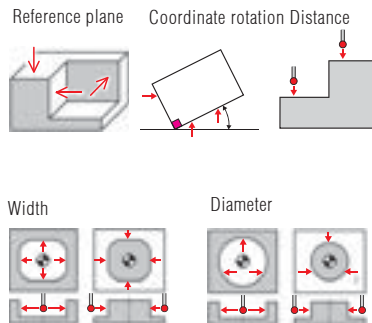

Maintenance functions

Help Guidance [F31i-B]

The screen will display detailed information regarding the machine alarm and will explain how to recover the machine from the problem. This screen will also display a list of G-codes and a description of M signals.

Display of details of alarms



Description of M signals



High-efficiency Control Technologies

Hyper HQ Control [Opt]

High-speed processing is enabled by improved capability of processing fine line segment toolpaths.

F31i-B/FAi capability of processing fine line segments

Type	Fine line segment data processing speed (m/min)		Instruction method
	F31i-B	FAi	
Without Hyper HQ control	15 (591 ipm)		
Hyper HQ control mode A	30 (1181 ipm)		ON: G05.1Q1; OFF: G05.1Q0
Hyper HQ control mode B	150 (5906 ipm)	—	ON: G05.1Q1; OFF: G05.1Q0

The above values show (theoretical) maximum speeds for processing 1-mm-segment blocks constructing a straight line. Actual processing speeds depend on the type of the machine and NC data.

HQ Tuner [Opt]

The HQ tuner provides the programmer a 10-step adjustment of parameters for hyper HQ control in accordance with processing conditions.

It adjusts the hyper HQ control in accordance with the current process.

For example, during roughing routines the programmer can place a higher priority on speed and in finishing routines a higher priority on dimensional accuracy at corners and circular arcs.



Technologies for Reduced Setup and Unmanned Operation

Soft AC [Opt]

The soft AC function applies the feed rate override control automatically so that the value of the spindle load meter does not change significantly. This helps to prevent damages of tools caused by overload and improve cutting efficiency.

- Adaptive control function
 - Feed override control range: 10 to 200%
 - (Changeable with parameters)
 - Alarms are output at the lower limit override value.
- Air-cut reduction function
 - Feed rates during non-cutting operation can be increased up to 200%.
 - (Changeable with parameters)
- Tool failure monitoring function
 - Specifications similar to the soft CCM.
- Continuous unmanned machining at the time of tool failure (option)
 - Combined operation with the automatic restart function is possible.

Soft CCM [Opt]

The Soft CCM monitors the spindle load meter, and stops operation when the meter value exceeds the preset value (set by M signal or set for each of the T numbers through setting screen) and generation of abnormal tool load is determined which is convenient for unmanned operation at night.

High-efficiency Control Technologies

Data Server [Opt]

A large amount of machining programs can be transferred to the data server through the network connected to the host computer at high speed. The transferred machining programs are executed as the main programs or sub-programs (called up by using the M198 signal.)

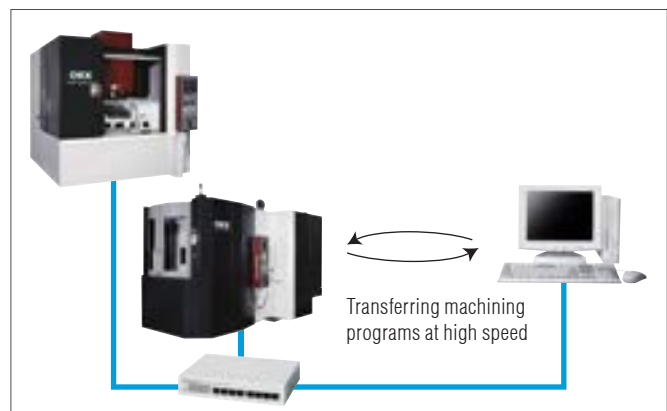

FANUC Controller F31i-B

(Windows CE-installed Open CNC)

Standard Specification
No. of controlled axes: 4 axes (X, Y, Z, B)
No. of simultaneously controlled axes: 3 axes (4 axes for BRT specification)
Least input increment: 0.001mm / 0.0001"
Max. programmable dimension: ±999999.999mm / ±39370.0787"
Absolute / Incremental command: G90 / G91
Decimal point input / Pocket calculator type decimal point input
Inch / Metric conversion: G20 / G21
Program code: ISO / EIA automatic discriminator
Program format: FANUC standard format
Nano interpolation (internal)
Positioning: G00
Linear interpolation: G01
Circular interpolation: G02 / G03 (CW / CCW), including radius designation
Cutting feed rate: 6.3-digit F-code, direct command
Dwell: G04
Manual handle feed: manual pulse generator 1 set(0.001, 0.01, 0.1mm)
Rapid traverse override: 0 / 1 / 10 / 25 / 50 / 100%
Cutting feed rate override: 0 to 200% (every 10%)
Feed rate override cancel: M49 / M48
Rigid tapping: G84, G74 (Mode designation: M29)
Part program storage capacity: 160m [64KB]
No. of registered programs: 120
Part program editing
Background editing
Extended part program editing
10.4" color LCD
Clock function
MDI (Manual Data Input) operation
Memory card interface
Spindle function: 5-digit S-code direct command
Spindle speed override: 50 to 150% (every 5%)
Tool function: 4-digit T-code direct command
ATC tool registration
Auxiliary function: 3-digit M-code programming
Multiple M-codes in 1 block: 3 codes (Max. 20 settings)
Tool length offset: G43, G44/G49
Tool diameter and cutting edge R compensation: G41, G42/G40
Tool offset sets: 99 sets in total
Tool offset memory C
Manual reference position return
Automatic reference position return: G28/G29
2nd reference position return: G30
Reference position return check: G27
Automatic coordinate system setting
Coordinate system setting: G92
Machine coordinate system: G53
Workpiece coordinate system: G54 to G59
Local coordinate system: G52
Program stop: M00
Optional stop: M01
Optional block skip: /
Dry run
Machine lock
Z-axis feed cancel
Auxiliary function lock
Graphic display
Program number search
Sequence number search

Standard Specification
Program restart
Cycle start
Auto restart
Single block
Feed hold
Manual absolute on/off: parameter
Sub program control
Canned cycle: G73, G74, G76, G80 to G89
Mirror image function: parameter
Automatic corner override
Exact stop check/mode
Programmable data input: G10
Backlash compensation for each rapid traverse and cutting feed
Smooth backlash compensation
Memory pitch error compensation (interpolation type)
Skip function
Tool length manual measurement
Emergency stop
Data protection key
NC alarm display / alarm history display
Machine alarm display
Stored stroke limit 1
Stored stroke limit 2, 3
Load monitor
Self-diagnosis
Absolute position detection
Manual guide i (Basic)

Optional Specification
15" color LCD
Additional one axis control: name of axis(A, B, C, U, V, W) *
Additional two axes control: name of axis(A, B, C, U, V, W) *
No. of simultaneously controlled axes: 5 axes *
Least input increment: 0.0001mm / 0.00001"
FS15 tape format
Unidirectional positioning: G60
Helical interpolation PK1
Cylindrical interpolation
Hypothetical axis interpolation
Spiral/Conical interpolation
Smooth interpolation (Hyper HQ control B mode is required)
NURBS interpolation (Hyper HQ control B mode is required)
Involute interpolation
One-digit F code feed
Handle feed 3 axes(Standard pulse handle is removed)
Part program storage capacity: 320m [128KB](250 in total)
Part program storage capacity: 640m [256KB](500 in total)
Part program storage capacity: 1280m [512KB](1000 in total) PK1
Part program storage capacity: 2560m [1MB](1000 in total)
Part program storage capacity: 5120m [2MB](1000 in total)
Part program storage capacity: 10240m [4MB](1000 in total)
Part program storage capacity: 20480m [8MB](1000 in total)
RS232C interface: RS232C-1CH
Data server: ATA card (1GB) PK2
Data server: ATA card (4GB)
Spindle contour control (Cs contour control)
Tool position offset
3-dimensional cutter compensation

Optional Specification
Tool offset sets: 200 sets in total PK1
Tool offset sets: 400 sets in total
Tool offset sets: 499 sets in total
Tool offset sets: 999 sets in total
Addition of workpiece coordinate system (48 sets in total): G54.1 P1 to P48 PK1
Addition of workpiece coordinate system (300 sets in total): G54.1 P1 to P300
Machining time stamp
Addition of optional block skip: 9 in total
Tool retract and return
Sequence number comparison and stop
Manual handle interruption
Programmable mirror image PK1
Optional chamfering / corner R
Custom macro PK1
Interruption type custom macro
Addition of custom macro common variables: 600
Figure copy
Coordinate system rotation: G68, G69
Scaling: G50, G51
Chopping (Axis control by PMC)
Playback
Tool life management: 256 sets in total PK1
Addition of tool life management sets: 1024 sets in total
High-speed skip
Run hour and parts count display PK1
Manual guide i (Milling cycle)

Original OKK Software
Machining support integrated software (including Help guidance, etc.) STD
Tool support STD
Program editor STD
EasyPRO STD
Work manager OP
HQ control STD
Hyper HQ control mode A OP
Hyper HQ control mode B PK2 OP
Hyper HQ value kit (including the items with "PK2") OP
NC option package (including the items with "PK1") OP
Special canned cycle (including circular cutting) OP
Cycle mate F OP
Soft scale Iim STD
Touch sensor T0 software OP
Tool failure detection system (Soft CCM) OP
Adaptive control (Soft AC) OP
Automatic restart at tool damage OP

*F31i-B5 (Windows CE-installed Open CNC) controller is required
STD: Standard OP: Option

FANUC Controller FAi

Standard Specification
No. of controlled axes: 4 axes (X, Y, Z, B)
No. of simultaneously controlled axes: 3 axes (4 axes for BRT specification)
Least input increment: 0.001mm / 0.0001"
Max.programmable dimension: ±999999.999mm / ±39370.0787"
Absolute / Incremental command: G90 / G91
Decimal point input / Pocket calculator type decimal point input
Inch / Metric conversion: G20 / G21
Program code: ISO / EIA automatic discriminaton
Program format: FANUC standard format
Nano interpolation(internal)
Positioning: G00
Linear interpolation: G01
Circular interpolation: G02 / G03 (CW / CCW), including radius designation
Unidirectional positioning: G60
Helical interpolation
Cylindrical interpolation
Cutting feed rate: 6.3-digit F-code, direct command
Dwell: G04
Manual handle feed: manual pulse generator 1 set (0.001, 0.01, 0.1mm)
Rapid traverse override: 0 / 1 / 10 / 25 / 50 / 100%
Cutting feed rate override: 0 to 200% (every 10%)
Feed rate override cancel: M49 / M48
Rigid tapping: G84, G74 (Mode designation: M29)
One-digit F code feed
Inverse time feed
Part program storage capacity: 1280m [512KB]
No. of registered programs: 400
Part program editing
Background editing
Extended part program editing
10.4" color LCD
Clock function
MDI(Manual Data Input) operation
Run hour and parts count display
Memory card interface
Spindle function: 5-digit S-code direct command
Spindle speed override: 50 to 150% (every 5%)
Tool function: 4-digit T-code direct command
ATC tool registration
Auxiliary function: 3-digit M-code programming
Multiple M-codes in 1 block: 3 codes (Max. 20 settings)
Tool length offset: G43, G44/G49
Tool diameter and cutting edge R compensation: G41, G42/G40
Tool offset sets: 400 sets in total
Tool offset memory C
Tool position offset
Manual reference position return
Automatic reference position return: G28/G29
2nd reference position return: G30
Reference position return check: G27
Automatic coordinate system setting
Coordinate system setting: G92
Machine coordinate system: G53
Workpiece coordinate system: G54 to G59
Local coordinate system: G52
Addition of workpiece coordinate system (48 sets in total): G54.1 P1 to P48
Program stop: M00
Optional stop: M01

Standard Specification
Optional block skip: /
Addition of optional block skip: 9 in total
Dry run
Machine lock
Z-axis feed cancel
Auxiliary function lock
Graphic display
Program number search
Sequence number search
Program restart
Cycle start
Auto restart
Single block
Feed hold
Manual absolute on/off: parameter
Sequence number comparison and stop
Manual handle interruption
Sub program control
Canned cycle: G73, G74, G76, G80 to G89
Mirror image function: parameter
Automatic corner override
Exact stop check/mode
Programmable data input: G10
Scaling: G50, G51
Custom macro
Interruption type custom macro
Addition of custom macro common variables: 600
Programmable mirror image
Coordinate system rotation: G68, G69
Optional chamfering / corner R
Manual guide i (Basic)
Backlash compensation for each rapid traverse and cutting feed
Memory pitch error compensation
Skip function
Tool length manual measurement
Tool life management: 128 sets in total
Emergency stop
Data protection key
NC alarm display / alarm history display
Machine alarm display
Stored stroke limit 1
Stored stroke limit 2, 3
Load monitor
Self-diagnosis
Absolute position detection

Optional Specification
Additional one axis control: name of axis (A, C, U, V, W) (No. of simultaneously controlled axes: 4 axes)
Additional two axes control: name of axis (A, C, U, V, W) (No. of simultaneously controlled axes: 4 axes)
FS11 tape format
Part program storage capacity: 5120m [2MB] (400 in total)
Data server: ATA card (1GB)
Spindle contour control (Cs contour control)
Manual guide i (Milling cycle)
High-speed skip
RS232C interface: RS232C-1CH

Original OKK Software	
HQ control	STD
Hyper HQ control mode A	OP
Soft scale IIm	STD
Special canned cycle (including circular cutting)	OP
Touch sensor T0 software	OP
Tool failure detection system (Soft CCM)	OP
Adaptive control (Soft AC)	OP
Automatic restart at tool damage	OP

STD: Standard OP: Option

Standard Specifications

Item		HM400/40	HM500S/40	HM400/50	HM500S/50
Travel on X axis (Column: right/left)	mm	630 (24.80")			
Travel on Y axis (Spindle head: up/down)	mm	620 (24.41")			
Travel on Z axis (Table: back/forth)	mm	710 (27.95")			
Distance from table top surface to spindle center	mm	80~700 (3.15"~27.55")	50~670 (1.97"~26.38")	80~700 (3.15"~27.55")	50~670 (1.97"~26.38")
Distance from table center to spindle nose	mm	150~860(5.91"~33.86")			
Pallet work surface area	mm	□400 (15.75")	□500 (19.69")	□400 (15.75")	□500 (19.69")
Max. weight loadable on pallet	kg	(Uniform load) 450 (992lbs)			
Pallet top surface configuration		25×M16tap			
Minimum indexable angle of table	deg	BRT 0.001 / IT[Opt] 1° ^{*1}			
Table index time (for indexing 90 degrees)	sec	BRT 0.5 / IT[Opt] 1.9			
Spindle speed	min ⁻¹	35~10,000		35~12,000	
Number of spindle speed change steps		Electric 2-step speed change (MS)			
Spindle inner taper		7/24 taper, No.40		7/24 taper, No.50	
Spindle bearing inner diameter	mm	ø80 (3.15")		ø100 (3.94")	
Rapid traverse rate	m/min	54 (2,126 ipm)			
Cutting feed rate	mm/min	1~40,000 (0.04~1574 ipm) ^{*2}			
Type of tool shank		JIS B 6339 BT40		JIS B 6339 BT50	
Type of pull stud		MAS403 P40T-1 (MASI)		OKK only 90°	
Tool storage capacity	tool	40 ^{*3}			
Maximum tool diameter	mm	ø82 (3.23") / ø160 (6.30") without tool in adjacent pot		ø115 (4.53") / ø250 (9.84") without tool in adjacent pot	
Maximum tool length (from the gauge line)	mm	400 (15.75")			
Maximum tool weight	kg	12 (26 lbs) with slow ATC cycle		25 (55 lbs) with slow ATC cycle	
Maximum tool moment	N·m	9.8 (7.2 ft · lbs)		29.4 (21.7 ft · lbs)	
Tool selection method		Address fixed random system			
Tool change time (cut-to-cut)	sec	3.3		4.2	
Pallet change method		Direct turn			
Pallet change time (JIS evaluation time)	sec	9.5			
Spindle motor	AC, kW	FANUC 37 (50HP)/26 (35HP) / 22 (30HP) (25%ED/30min/cont. rating)		FANUC 30 (40HP) / 25 (34HP) (30min/cont. rating)	
Feed motor (X,Y,Z,B)	kW	FANUC 5.5 (7.4HP) / 5.5 (7.4HP) / 4.5 (6.0HP) /BRT: 4.5 (6.0HP) (IT[Opt]: 4.5 (6.0HP))			
Hydraulic pump motor	kW	1.5 (2.0HP)			
Motor of oil cooler for spindle and feed system(compression/discharge)	kW	1.1 (1.5HP) / 0.4 (0.5HP)			
Coolant pump motor	kW	50Hz: 0.7 (0.9HP) 60Hz: 1.2 (1.6HP)			
Power supply AC200V±10% 50/60±1Hz AC220V±10% 60±1Hz ^{*4}	kVA	FANUC 56		FANUC 62	
Compressed air supply	MPa, ℓ/min [ANR]	0.4~0.6 ^{*5} , 500 ^{*6} (58~87 psi, 132 gal/min)			
Hydraulic unit tank capacity	ℓ	20 (5.3 gal)			
Spindle and feed system cooling oil tank capacity	ℓ	20 (5.3gal)			
Coolant tank capacity	ℓ	480 (127 gal)			
Machine height	mm	2844 (111.97")		2970 (116.93")	
Required floor space	mm	Refer to the floor space drawing.			
Machine weight	kg	12,000 (26,455 lbs)	12,200 (26,896 lbs)	12,500 (27,557 lbs)	12,700 (27,998 lbs)
Operating environment temperature	°C	5~40			

*1 BRT: Built-in rotary table minimum indexing 0.001° IT: Index table minimum indexing 1°

*2 Available under the HQ or hyper HQ control.

*3 The number of stored tools refers a total number of tools including the one installed on the spindle i.e. subtract one from the above for actual number of tools stored in the tool magazine.

*4 When the supply voltage is 220VAC, the supply frequency of 60Hz only is applicable.

*5 Purity of compressed air should be class 3.5.4 or higher class of ISO 8573-1/JIS B8392-1 standard.

*6 Specified is the compressed air supply flow rate for standard specification machines. When optional specifications such as an air blow nozzle are added, add the corresponding air supply requirement.

Machine Dimensions

mm(in)

Floor Space

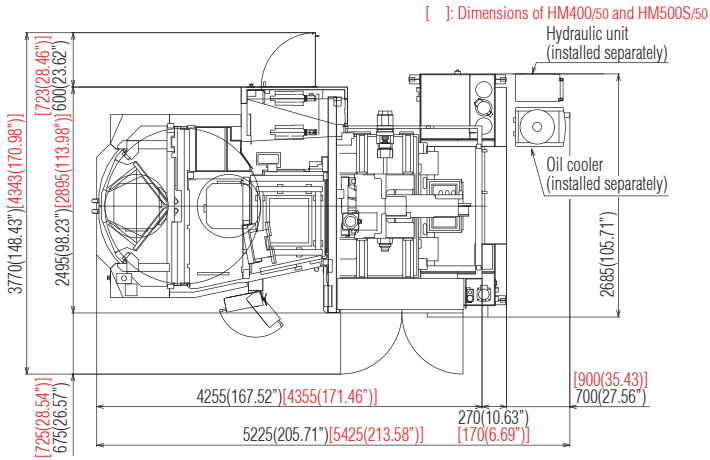

Front View

Lift up chip conveyor [Opt]

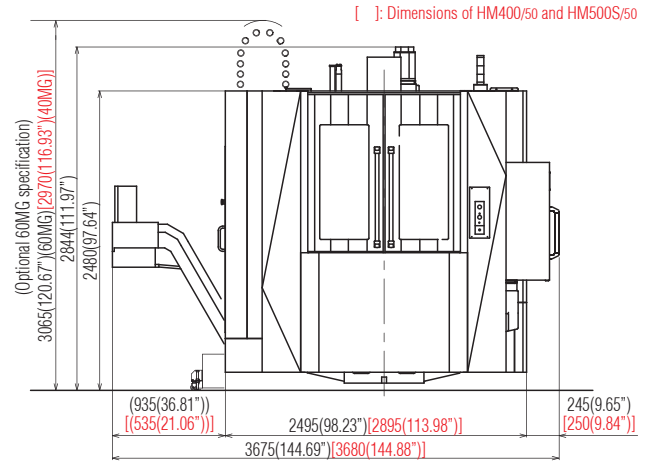

Pallet Dimensions

Tap specification [Std]

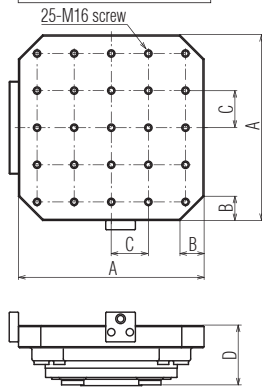

T-slot specification [Opt]

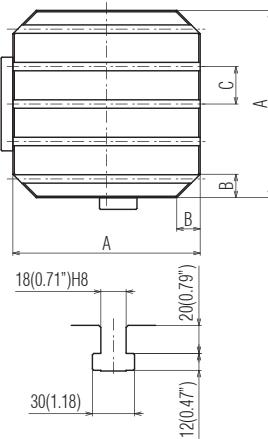

□* edgelocater[Opt]

Pallet dimensions

mm(in)

	A	B	C	D
HM400	400(15.8")	50(1.97")	80(3.15")	130(5.12")
HM500S	500(19.7")	65(2.56")	100(3.94")	160(6.30")
HM400(T-slot)	400(15.8")	50(1.97")	80(3.15")	160(6.30")
HM500S(T-slot)	500(19.7")	65(2.56")	100(3.94")	190(7.48")

Restriction on Tool

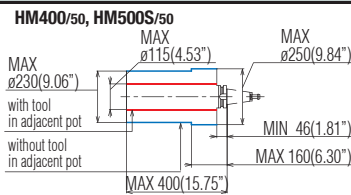
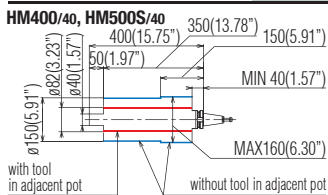

XYZ axis travel diagrams

mm(in)

	A	B	C	D	E	F	G	H
HM400	400(15.75")	900(35.43")	700(27.56")	80(3.15")	160(6.30")	200(7.87")	50(1.97")	110(4.33")
HM500S	500(19.69")	870(34.25")	670(26.38")	50(1.97")	190(7.48")	250(9.84")	61(2.40")	90(3.54")
HM400(T-slot)	400(15.75")	870(34.25")	670(26.38")	50(1.97")	160(6.30")	200(7.87")	50(1.97")	110(4.33")
HM500S(T-slot)	500(19.69")	840(33.07")	640(25.20")	20(0.79")	190(7.48")	250(9.84")	61(2.40")	90(3.54")

XYZ axes travel diagrams

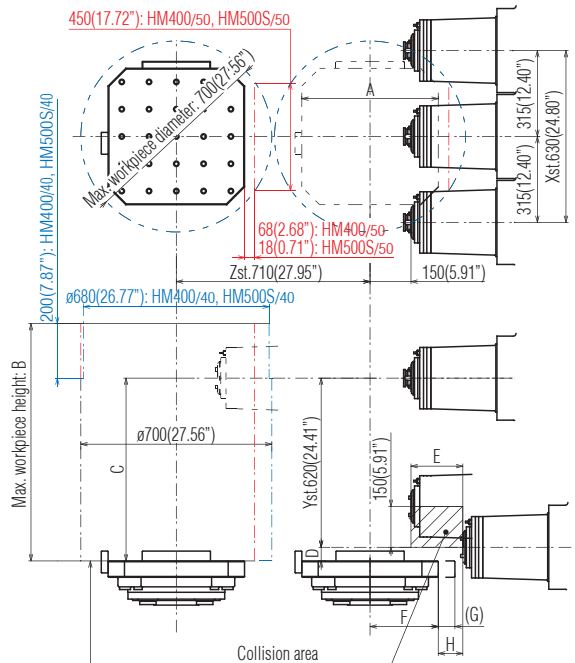

Dimensions and shape of workpiece :

Blue-colored section: Dimensions and shape for HM400/40 and HM500S/40

Red-colored section: Dimensions and shape for HM400/50 and HM500S/50

Black-colored section: Dimensions and shape being common to the machines

Standard Specifications

Item		HM5100	HM6000S
Travel on X axis (Column: right/left)	mm	800 (31.50")	
Travel on Y axis (Spindle head: up/down)	mm	750 (29.53")	
Travel on Z axis (Table: back/forth)	mm	880 (34.65")	
Distance from table top surface to spindle center	mm	80-830 (3.15"-32.68")	50-800 (1.96"-31.50")
Distance from table center to spindle nose	mm	70-950 (2.76"-37.40")	
Pallet work surface area	mm	□ 500 (19.69")	□ 630 (24.80")
Max. weight loadable on pallet	kg	(Uniform load) 800 (1763 lbs)	(Uniform load) 700 (1543 lbs)
Pallet top surface configuration		24xM16lap	
Minimum indexable angle of table	°	BRT 0.001 / IT [Opt] 1*1	
Table index time (for indexing 90 degrees)	sec	BRT 0.5 / IT [Opt] 1.7	
Spindle speed	min ⁻¹	35-12,000	
Number of spindle speed change steps		Electric 2-step speed change (MS)	
Spindle inner taper		7/24 taper, No.50	
Spindle bearing inner diameter	mm	ø100 (3.94")	
Rapid traverse rate	m/min	X,Z: 75 (2,953 ipm) Y: 60 (2,362 ipm)	
Cutting feed rate	mm/min	1-40,000 (0.04~1574 ipm)**2	
Type of tool shank		JIS B 6339 BT50	
Type of pull stud		OKK only 90°	
Tool storage capacity	tool	60*3	
Maximum tool diameter	mm	ø115 (4.53") / ø300 (11.81") without tool in adjacent pots	
Maximum tool length (from the gauge line)	mm	600 (23.62")	
Maximum tool weight	kg	When turning at normal speed: 10; When slow turning is selected: 30	
Maximum tool moment	N-m	29.4 (21.68 ft · lbs)	
Tool selection method		Address fixed random system	
Tool change time (cut-to-cut)	sec	3.7	3.6
Pallet change method		Direct turn	
Pallet change time (JIS evaluation time)	sec	10.5	
Spindle motor (25%ED/30min/cont. rating)	AC, kW	FANUC 45 (60HP) / 30 (40HP) / 26 (35HP)	
Motor for ATC (Automatic Tool Changer)	kW	1.5 (2HP)	
Feed motor (X,Y,Z,B)	kW	FANUC 5.5 (7.4HP) / 5.5 (7.4HP) / 5.5 (7.4HP) / BRT: 4.5 (6.0HP) (IT[Opt]: 1.6 (2.1HP))	
Hydraulic pump motor	kW	1.5 (2HP)	
Motor of oil cooler for spindle and feed system (compression/discharge)	kW	1.1 (1.5HP) / 0.4 (0.5HP)	
Coolant pump motor	kW	50Hz: 0.7 (0.9HP) 60Hz: 1.2 (1.6HP)	
Power supply AC200V±10% 50/60±1Hz AC220V±10% 60±1Hz*4	kVA	FANUC 58	
Compressed air supply	MPa, ℓ/min [ANR]	0.4-0.6*5, 500*6 (58-87 psi, 132 gal/min)	
Hydraulic unit tank capacity	ℓ	20 (5.3 gal)	
Spindle and feed system cooling oil tank capacity	ℓ	20 (5.3 gal)	
Magazine lubricating oil tank capacity	ℓ	4.2 (0.3 gal)	
Coolant tank capacity	ℓ	720 (190 gal) (Option for the lift up type chip conveyor specification)	
Machine height	mm	4115 (162.01")	
Required floor space	mm	3,655x5,380 (143.90"x211.81") (Option for the lift up type chip conveyor specification)	
Machine weight	kg	15,700 (34,612 lbs)	16,000 (35,273 lbs)
Operating environment temperature	°C	5-40	

*1 BRT: Built-in rotary table minimum indexing 0.001° IT: Index table minimum indexing 1°

*2 Available under the HQ or hyper HQ control.

*3 The number of stored tools refers a total number of tools including the one installed on the spindle i.e. subtract one from the above for actual number of tools stored in the tool magazine.

*4 When the supply voltage is 220VAC, the supply frequency of 60Hz only is applicable.

*5 Purity of compressed air should be class 3.5.4 or higher class of ISO 8573-1/JIS B8392-1 standard.

*6 Specified is the compressed air supply flow rate for standard specification machines. When optional specifications such as an air blow nozzle are added, add the corresponding air supply requirement.

Machine Dimensions

mm(in)

Floor Space

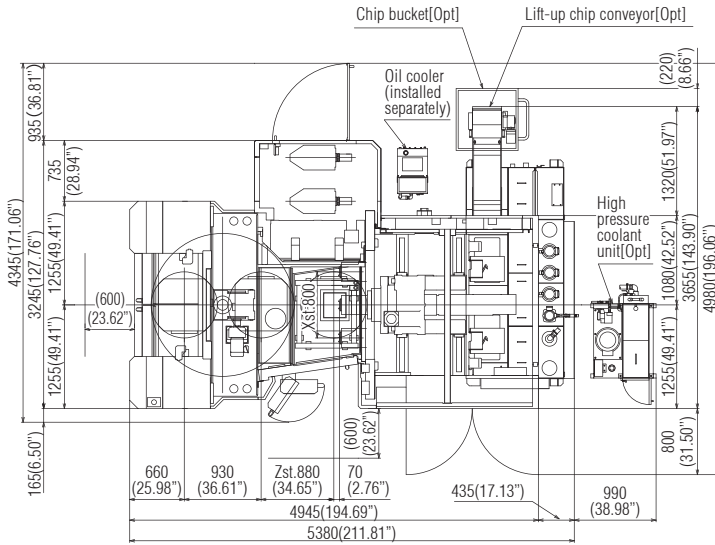

Front View

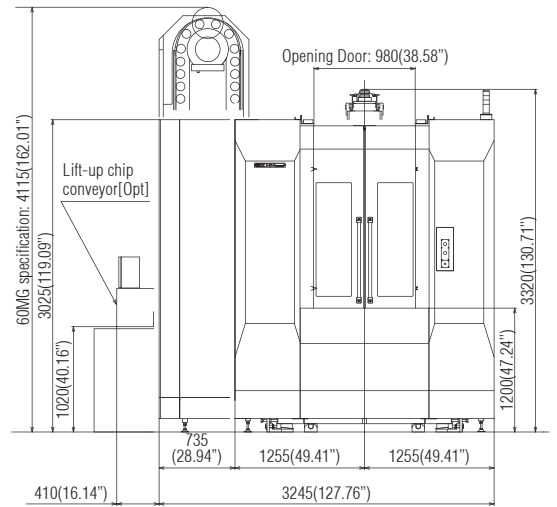

Pallet Dimensions

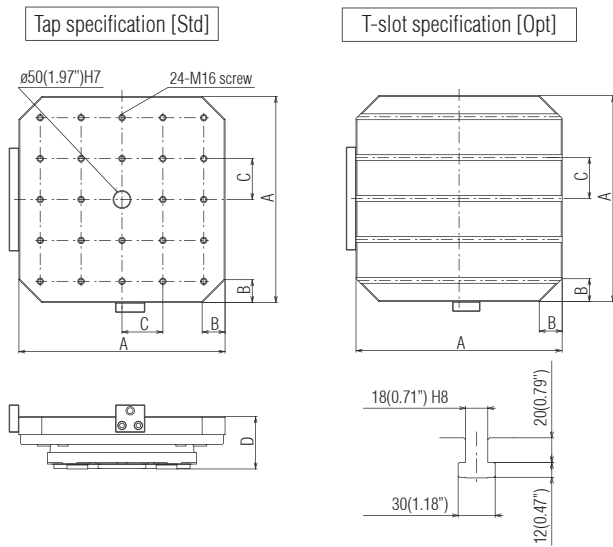

Restriction on Tool

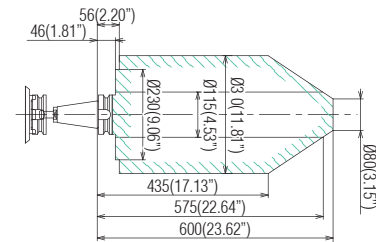

XYZ axes travel diagrams

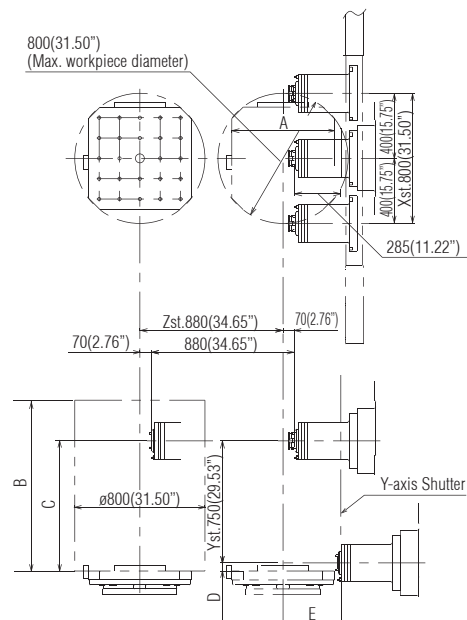

Pallet dimensions

	mm(in)			
	A	B	C	D
HM5100	500(19.69")	60(2.36")	100(3.94")	130(5.12")
HM6000S	630(24.80")	70(2.76")	125(4.92")	160(6.30")

Notes: Tap and T-slot are same dimensions.

XYZ axis travel diagrams

	mm(in)				
	A	B	C	D	E
HM5100	500(19.69")	1330(52.36")	830(32.68")	80(3.15")	271(10.67") ¹
HM6000S	630(24.8")	1300(51.18")	800(31.5")	50(1.97")	336(13.23") ²

¹ At B-axis rotated 0°/90°/180°/270°: 250mm (9.84").
² At B-axis rotated 0°/90°/180°/270°: 315mm (12.40").

Notes: Tap and T-slot are same dimensions.

Standard Specifications

Item		HM630	HM800S
Travel on X axis (Column: right/left)	mm	1050 (41.34")	
Travel on Y axis (Spindle head: up/down)	mm	900 (35.43")	
Travel on Z axis (Table: back/forth)	mm	900 (35.43")	880 (34.65")
Distance from pallet top surface to spindle center	mm	80-980 (3.15"-38.58")	60-960 (2.36"-37.80")
Distance from pallet center to spindle nose	mm	200-1100 (7.87"-43.31")	220-1100 (8.66"-43.31")
Pallet work surface area	mm	□ 630 (24.80")	□ 800 (31.50")
Max. weight loadable on pallet	kg	(Uniform load) 1300 (2866 lbs)	(Uniform load) 1200 (2645 lbs)
Pallet top surface configuration		24xM16 tap	
Minimum indexable angle of table	°	BRT 0.001 / IT [Opt] 1**1	
Table index time (for indexing 90 degrees)	sec	BRT 0.6 / IT [Opt] 1.7	
Spindle speed	min ⁻¹	35-12,000	
Number of spindle speed change steps		Electric 2-step speed change (MS)	
Spindle inner taper		7/24 taper, No.50	
Spindle bearing inner diameter	mm	ø100 (3.94")	
Rapid traverse rate	m/min	54 (2,126 ipm)	
Cutting feed rate	mm/min	1-40,000 (0.04-1574 ipm)**2	
Type of tool shank		JIS B 6339 BT50	
Type of pull stud		OKK only 90°	
Tool storage capacity	tool	40**3	
Maximum tool diameter	mm	ø115 (4.53") / ø270 (10.63") without tool in adjacent pots	
Maximum tool length (from the gauge line)	mm	500 (19.69")	
Maximum tool weight	kg	25 (55 lbs)	
Maximum tool moment		29.4 (21.7 ft · lbs)	
Tool selection method		Address fixed random system	
Tool change time (cut-to-cut)	sec	4.4	
Pallet change method		Direct turn	
Pallet change time (JIS evaluation time)	sec	15.0	
spindle motor (25%ED/30min/cont. rating)	AC, kW	FANUC 45 (60HP) / 30 (40HP) / 26 (35HP)	
Motor for tool clamp/unclamp unit	kW	0.75 (1.0HP)	
Feed motor (X, Y, Z, B)	kW	FANUC 5.5 (7.4HP) / 5.5 (7.4HP) / 5.5(7.4HP) / BRT: 4.5 (6.0HP) (IT[Opt]: 2.7 (3.6HP))	
Hydraulic pump motor	kW	1.5 (2.0HP)	
Motor of oil cooler for spindle and feed system (compression/discharge)	kW	1.7(2.3 HP) / 0.75 (1.0 HP)	
Coolant pump motor	kW	50Hz: 0.7 (0.9HP) 60Hz: 1.2 (1.6HP)	
Motor for APC unit	kW	0.75 (1.0 HP)	
Power supply 200VAC ±10% 50/60 ±1Hz 220VAC ±10% 60 ±1Hz ⁴	kVA	FANUC 65	
Compressed air supply	MPa, ℓ/min [ANR]	0.4~0.6**5, 500**6 (58~87 psi, 132 gal/min)	
Hydraulic unit tank capacity	ℓ	20 (5.3 gal)	
Spindle and feed system cooling oil tank capacity	ℓ	70 (18.5 gal)	
Magazine lubricating oil tank capacity	ℓ	1 (0.3 gal)	
Coolant tank capacity	ℓ	400 (106 gal)	
Machine height	mm	3,430 (135.04")	
Required floor space	mm	3,420x5,450 (134.65"x214.57")	
Machine weight	kg	18,000 (39700 lbs)	18,500 (40800 lbs)
Operating environment temperature	°C	5-40	

*1 BRT: Built-in rotary table minimum indexing 0.001° IT: Index table minimum indexing 1°

*2 Available under the HQ or hyper HQ control.

*3 The number of stored tools refers a total number of tools including the one installed on the spindle i.e. subtract one from the above for actual number of tools stored in the tool magazine.

*4 When the supply voltage is 220VAC, the supply frequency of 60Hz only is applicable.

*5 Purity of compressed air should be class 3.5.4 or higher class of ISO 8573-1/JIS B8392-1 standard.

*6 Specified is the compressed air supply flow rate for standard specification machines. When optional specifications such as an air blow nozzle are added, add the corresponding air supply requirement.

Dimensions

mm(in)

Floor Space

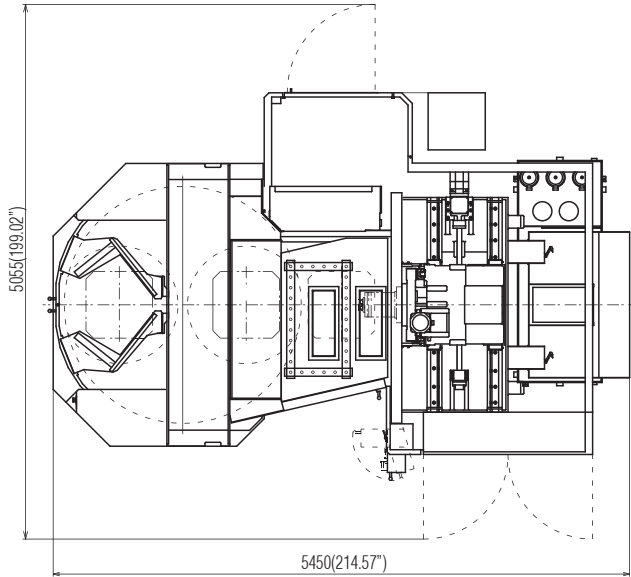

Front View

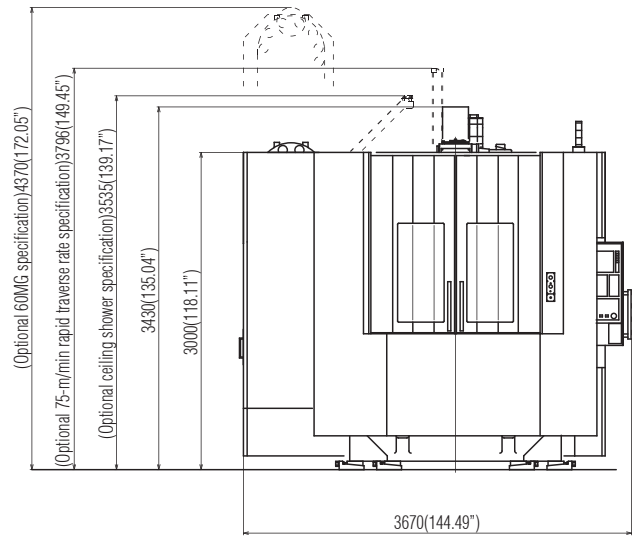

Pallet Dimensions

Tap specification [Std]

T-slot specification [Opt]

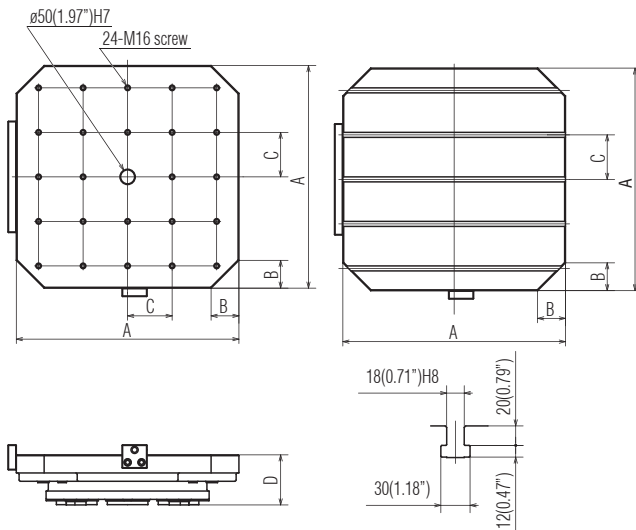

Pallet dimensions

mm(in)

	A	B	C	D
HM630	630(24.8")	70(2.76")	125(4.92)	160(6.30")
HM800S	800(31.5")	100(3.94")	160(6.30")	180(7.09")
HM800S(T-slot)	800(31.50")	100(3.94")	160(6.30")	200(7.87")

HM630: Tap and T-slot are same dimensions.

Restriction on Tool

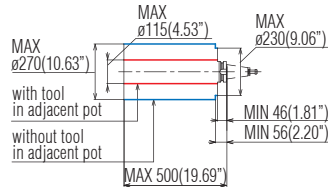

XYZ axes travel diagrams

(Note 1)

For executing the APC operation, the loaded workpiece must not exceed the specified maximum APC turning diameter.

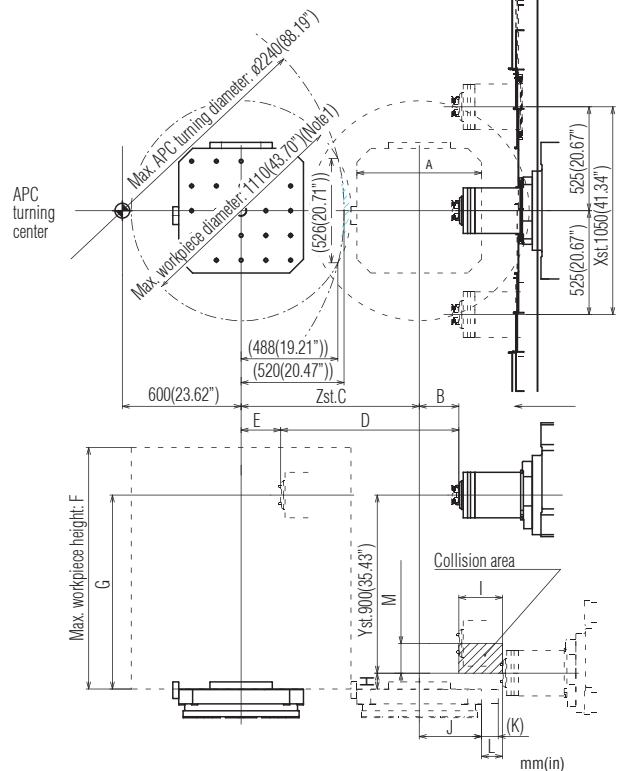

XYZ axis travel diagrams

	A	B	C	D	E	F	G	H	I	J	K	L	M
HM630	630(24.8")	200(7.87")	900(35.43")	900(35.43")	200(7.87")	1220(48.03")	980(38.58")	80(3.15")	220(8.66")	315(12.4")	84(3.31")	105(4.13")	150(5.91")
HM800S	800(31.5")	220(8.66")	880(34.65")	880(34.65")	220(8.66")	1200(47.24")	960(37.80")	60(2.36")	300(11.81")	400(15.75")	100(3.94")	120(4.72")	150(5.91")
HM800S(T-slot)	800(31.50")	220(8.66")	880(34.65")	880(34.65")	220(8.66")	1180(46.46")	940(37.01")	40(1.57")	300(11.81")	400(15.75")	100(3.94")	120(4.72")	170(6.69")

HM630: Tap and T-slot are same dimensions.

Standard Specifications

Item		HM800	HM1000S
Travel on X axis (Column: right/left)	mm	1400 (55.12")	
Travel on Y axis (Spindle head: up/down)	mm	1100 (43.31")	
Travel on Z axis (Table: back/forth)	mm	1050 (41.34")	1000 (39.37")
Distance from pallet top surface to spindle center	mm	60-1160 (2.36"-45.67")	30-1130 (1.18"-44.49")
Distance from pallet center to spindle nose	mm	200-1250 (7.87"-49.21")	250-1250 (9.84"-49.21")
Pallet work surface area	mm	□ 800 (31.50")	□ 1000 (39.37")
Max. weight loadable on pallet	kg	(Uniform load) 2000 (4400 lbs)	(Uniform load) 2500 (5500 lbs)
Pallet top surface configuration		24xM16 tap	
Minimum indexable angle of table	°	IT 1/ BRT [Opt] 0.001*1	
Table index time (for indexing 90 degrees)	sec	IT 4.5 / BRT [Opt] 1.2	IT 5.5 / BRT [Opt] 1.2
Spindle speed	min ⁻¹	35-8,000	
Number of spindle speed change steps		Electric 2-step speed change (MS)	
Spindle inner taper		7/24 taper, No.50	
Spindle bearing inner diameter	mm	ø100 (3.94")	
Rapid traverse rate	m/min	48 (1,889 ipm)	
Cutting feed rate	mm/min	1-40,000 (0.04-1574 ipm)*2	
Type of tool shank		JIS B 6339 BT50	
Type of pull stud		OKK only 90°	
Tool storage capacity	tool	40*3	
Maximum tool diameter	mm	ø115 (4.53") / ø270 (10.63") without tool in adjacent pots	
Maximum tool length (from the gauge line)	mm	500 (19.69")	
Maximum tool weight	kg	25 (55 lbs)	
Maximum tool moment		29.4 (21.7 ft · lbs)	
Tool selection method		Address fixed random system	
Tool change time (cut-to-cut)	sec	5.8	
Pallet change method		Direct turn	
Pallet change time (JIS evaluation time)	sec	19.0	21.0
spindle motor (30min/cont. rating)	AC, kW	FANUC 30 (40HP) / 25 (34HP)	
Motor for tool clamp/unclamp unit	kW	0.75 (1.0HP)	
Feed motor (X, Y, Z, B)	kW	FANUC 5.5 (7.4HP) / 9.0 (12.1HP) / 6.0 (8.0HP) / IT: 2.7 (3.6HP) (BRT[Opt]: 4.5 (6.0HP))	
Hydraulic pump motor	kW	1.5 (2.0HP)	
Motor of oil cooler for spindle and feed system (compression/discharge)	kW	1.7 (2.3HP) / 0.75 (1.0HP)	
Coolant pump motor	kW	50Hz: 0.7 (0.9HP) 60Hz: 1.2 (1.6HP)	
Motor for APC unit	kW	0.75 (1.0HP)	
Power supply 200VAC ±10% 50/60 ±1Hz 220VAC ±10% 60 ±1Hz*4	kVA	FANUC 61	
Compressed air supply	Pa, ℓ/min [ANR]	0.4-0.6*5, 500*6 (58-87 psi, 132 gal/min)	
Hydraulic unit tank capacity	ℓ	20 (5.3 gal)	
Spindle and feed system cooling oil tank capacity	ℓ	72 (19 gal)	
Magazine lubricating oil tank capacity	ℓ	1 (0.3 gal)	
Coolant tank capacity	ℓ	800 (211 gal)	
Machine height	mm	4,000 (157.48")	
Required floor space	mm	3,682x6,395 (144.96"x251.77")	
Machine weight	kg	24,500 (54,000 lbs)	25,000 (55,000 lbs)
Operating environment temperature		5~40	

*1 BRT: Built-in rotary table minimum indexing 0.001° IT: Index table minimum indexing 1°

*2 Available under the HQ or hyper HQ control.

*3 The number of stored tools refers a total number of tools including the one installed on the spindle i.e. subtract one from the above for actual number of tools stored in the tool magazine.

*4 When the supply voltage is 220VAC, the supply frequency of 60Hz only is applicable.

*5 Purity of compressed air should be class 3.5.4 or higher class of ISO 8573-1/JIS B8392-1 standard.

*6 Specified is the compressed air supply flow rate for standard specification machines. When optional specifications such as an air blow nozzle are added, add the corresponding air supply requirement.

Dimensions

mm(in)

Floor Space

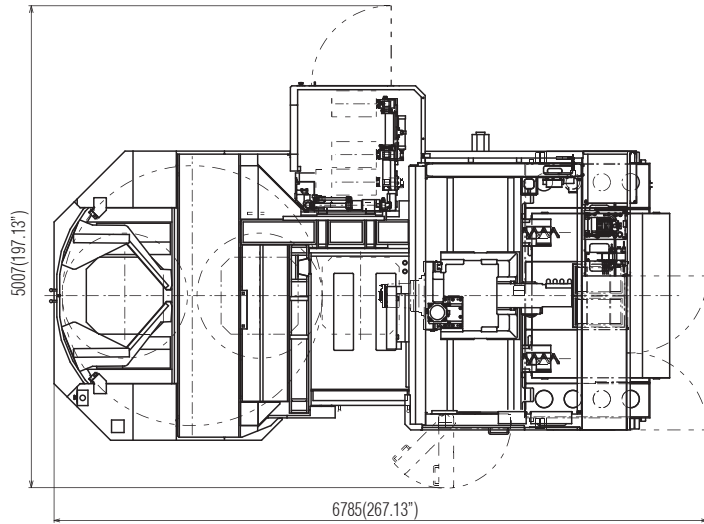

Front View

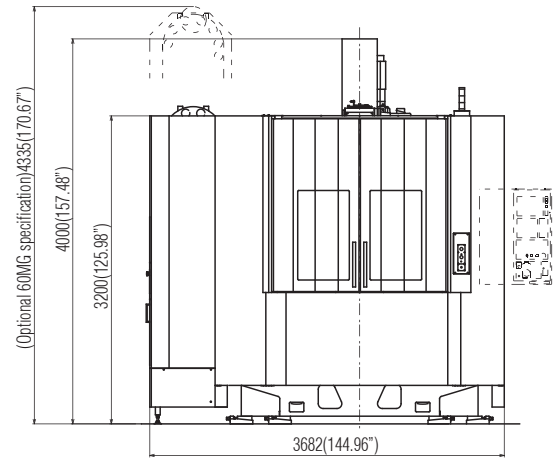

Pallet Dimensions

Tap specification [Std]

T-slot specification [Opt]

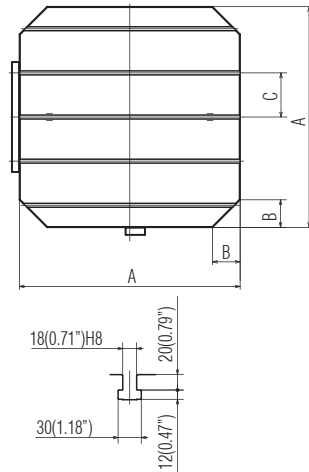
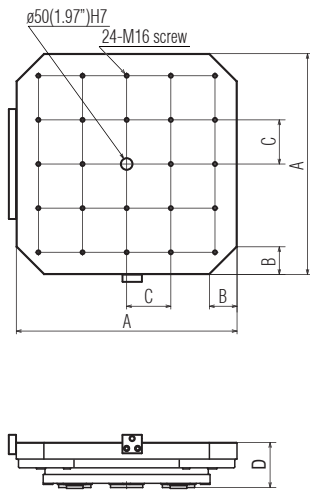

Restriction on Tool

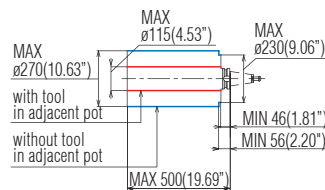

Pallet dimensions

	mm(in)			
	A	B	C	D
HM800	800(31.5")	100(3.94")	160(6.30")	174(6.85")
HM1000S	1000(39.37")	125(4.92")	200(7.87")	204(8.03")
HM800(T-slot)	800(31.5")	100(3.94")	160(6.30")	204(8.03")
HM1000S(T-slot)	1000(39.37")	125(4.92")	200(7.87")	214(8.43")

XYZ axis travel diagrams

	mm(in)												
	A	B	C	D	E	F	G	H	I	J	K	L	M
HM800	800(31.5")	200(7.87")	1050(41.34")	1050(41.34")	200(7.87")	1300(51.18")	1160(45.67")	60(2.36")	320(12.6")	400(15.75")	100(3.94")	120(4.72")	140(5.51")
HM1000S	1000(39.37")	250(9.84")	1000(39.37")	1000(39.37")	250(9.84")	1270(50.00")	1130(44.49")	30(1.18")	400(15.75")	500(19.69")	125(4.92")	150(5.91")	140(5.51")
HM800(T-slot)	800(31.5")	200(7.87")	1050(41.34")	1050(41.34")	200(7.87")	1270(50.00")	1130(44.49")	30(1.18")	320(12.6")	400(15.75")	100(3.94")	120(4.72")	140(5.51")
HM1000S(T-slot)	1000(39.37")	250(9.84")	1000(39.37")	1000(39.37")	250(9.84")	1260(49.61")	1120(44.09")	20(0.79")	400(15.75")	500(19.69")	125(4.92")	150(5.91")	150(5.91")

XYZ axes travel diagrams

(Note1)

For executing the APC operation, the loaded workpiece must not exceed the specified maximum APC turning diameter.

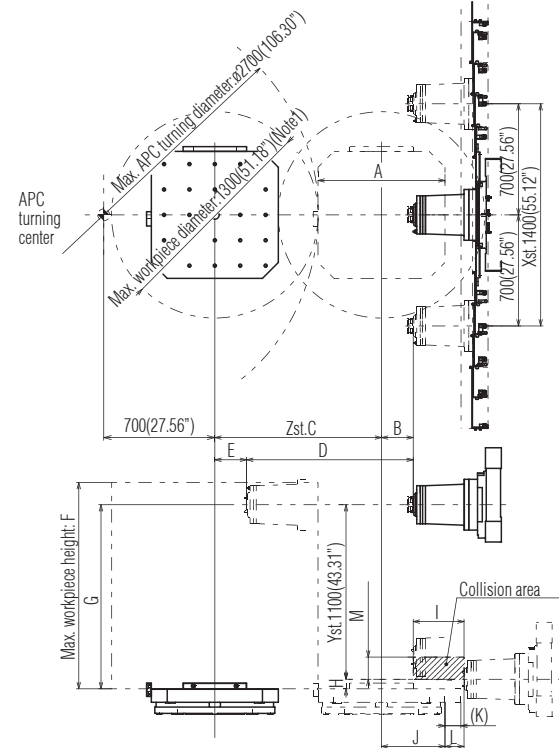

Standard Specifications

Item		HM1000	HM1250S
Travel on X axis (Column: right/left)	mm	1700 (66.93")	
Travel on Y axis (Spindle head: up/down)	mm	1400 (55.12")	
Travel on Z axis (Table: back/forth)	mm	1400 (55.12")	1240 (48.82")
Distance from pallet top surface to spindle center	mm	100-1500 (3.94"-59.06")	70-1470 (2.76"-57.87")
Distance from pallet center to spindle nose	mm	200-1600 (7.87"-62.99")	360-1600 (14.17"-62.99")
Pallet work surface area	mm	□ 1000 (39.37")	□ 1250 (49.21")
Max. weight loadable on pallet	kg	(Uniform load) 3000 (6600 lbs)	
Pallet top surface configuration		24xM16 tap	24xM20 tap
Minimum indexable angle of table	°	IT 1/ BRT [Opt] 0.0001*1	
Table index time (for indexing 90 degrees)	sec	IT 5.0 / BRT [Opt] 1.8	
Spindle speed	min ⁻¹	35-12,000	
Number of spindle speed change steps		Electric 2-step speed change (MS)	
Spindle inner taper		7/24 taper, No.50	
Spindle bearing inner diameter	mm	ø100 (3.94")	
Rapid traverse rate	m/min	48 (1,889 ipm)	
Cutting feed rate	mm/min	1-20,000 (0.04-787 ipm)*2	
Type of tool shank		JIS B 6339 BT50	
Type of pull stud		OKK only 90°	
Tool storage capacity	tool	40*3	
Maximum tool diameter	mm	ø115 (4.53") / ø270 (10.63") without tool in adjacent pots	
Maximum tool length (from the gauge line)	mm	600 (23.62")	
Maximum tool weight	kg	25 (55 lbs)	
Maximum tool moment	N·m	29.4 (21.7 ft·lbs)	
Tool selection method		Address fixed random system	
Tool change time (cut-to-cut)	sec	6.2	
Pallet change method		Direct turn	
Pallet change time (JIS evaluation time)	sec	32.0	35.0
spindle motor (30min/cont. rating)	AC, kW	FANUC 30 (40HP) / 25 (34HP)	
Motor for tool clamp/unclamp unit	kW	0.75 (1.0HP)	
Feed motor (X, Y, Z, B)	kW	FANUC 5.0 (6.7HP) / 5.5x2 (7.4x2HP) / 5.0x2 (6.7x2HP) / IT: 3.0 (4.0HP) (BRT[Opt]: 5.5 (7.4HP))	
Hydraulic pump motor	kW	2.2 (3.0HP)	
Motor of oil cooler for spindle and feed system (compression/discharge)	kW	1.7 (2.3HP) / 0.75x2 (1.0x2HP)	
Coolant pump motor	kW	50Hz: 0.7 (0.9HP) 60Hz: 1.2 (1.6HP)	
Motor for APC unit	kW	FANUC]: 1.2 (1.6HP)	
Power supply 200VAC ±10% 50/60 ±1Hz 220VAC ±10% 60 ±1Hz*4	kVA	FANUC 72	
Compressed air supply	MPa, ℓ/min [ANR]	0.4-0.6*5, 500*6 (58-87 psi, 132 gal/min)	
Hydraulic unit tank capacity	ℓ	20 (5.3 gal)	
Spindle and feed system cooling oil tank capacity	ℓ	70x2 (18.5x2 gal)	
Magazine lubricating oil tank capacity	ℓ	4 (1.1 gal)	
Coolant tank capacity	ℓ	800 (211 gal)	
Machine height	mm	3,717 (146.34")	
Required floor space	mm	5,530x8,195 (217.72"x322.64")	
Machine weight	kg	31,000 (68,400 lbs)	32,500 (72,000 lbs)
Operating environment temperature	°C	5-40	

*1 BRT: Built-in rotary table minimum indexing 0.001° IT: Index table minimum indexing 1°

*2 Available under the HQ or hyper HQ control.

*3 The number of stored tools refers a total number of tools including the one installed on the spindle i.e. subtract one from the above for actual number of tools stored in the tool magazine.

*4 When the supply voltage is 220VAC, the supply frequency of 60Hz only is applicable.

*5 Purity of compressed air should be class 3.5.4 or higher class of ISO 8573-1/JIS B8392-1 standard.

*6 Specified is the compressed air supply flow rate for standard specification machines. When optional specifications such as an air blow nozzle are added, add the corresponding air supply requirement.

Dimensions

mm(in)

Floor Space

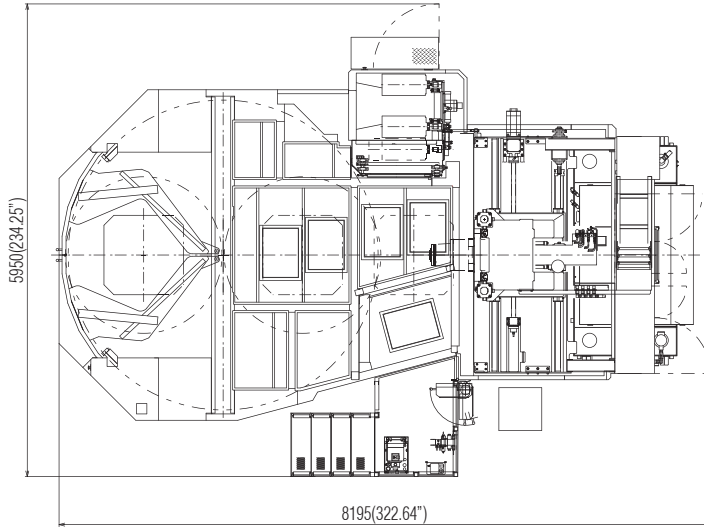

Front View

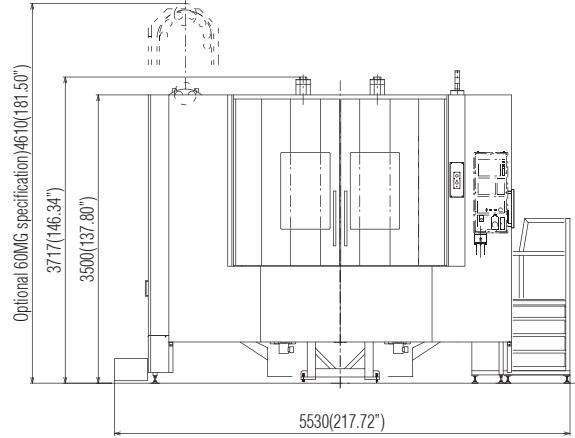

Pallet Dimensions

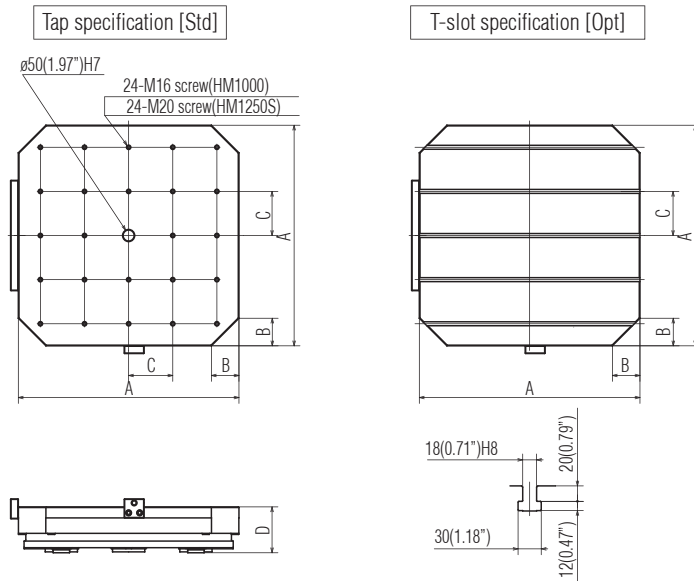

Pallet dimensions

	A	B	C	D
HM1000	1000 (39.37")	125 (4.92")	200 (7.87")	208 (8.19")
HM1000(T-slot)	1000 (39.37")	125 (4.92")	200 (7.87")	238 (9.37")
HM1250S	1250 (49.21")	125 (4.92")	250 (9.84")	238 (9.37")
HM1250S(T-slot)	1250 (49.21")	125 (4.92")	250 (9.84")	258 (10.16")

Restriction on Tool

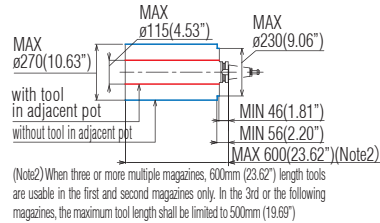

XYZ axes travel diagrams

(Note1)

For executing the APC operation, the loaded workpiece must not exceed the specified maximum APC turning diameter.

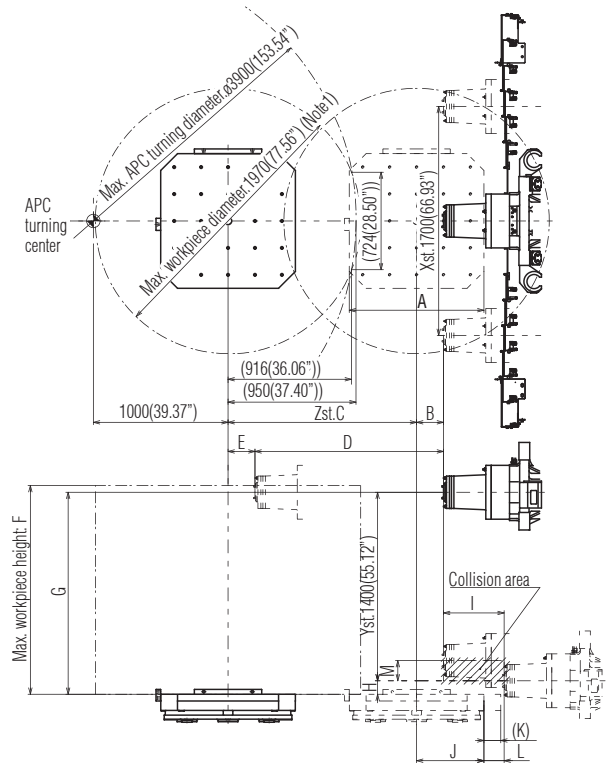

XYZ axis travel diagrams

	A	B	C	D	E	F	G	H	I	J	K	L	M
HM1000	1000 (39.37")	200 (7.87")	1400 (55.12")	1400 (55.12")	200 (7.87")	1550 (61.02")	1500 (59.06")	100 (3.94")	450 (17.72")	500 (19.69")	125 (4.92")	150 (5.91")	150 (5.91")
HM1000(T-slot)	1000 (39.37")	200 (7.87")	1400 (55.12")	1400 (55.12")	200 (7.87")	1520 (59.84")	1470 (57.87")	70 (2.76")	450 (17.72")	500 (19.69")	125 (4.92")	150 (5.91")	180 (7.09")
HM1250S	1250 (49.21")	360 (14.17")	1240 (48.82")	1240 (48.82")	360 (14.17")	1520 (59.84")	1470 (57.87")	70 (2.76")	470 (18.50")	625 (24.61")	175.4 (6.91")	205 (8.07")	180 (7.09")
HM1250S(T-slot)	1250 (49.21")	360 (14.17")	1240 (48.82")	1240 (48.82")	360 (14.17")	1500 (59.06")	1450 (57.09")	50 (1.97")	470 (18.50")	625 (24.61")	175.4 (6.91")	205 (8.07")	180 (7.09")



65 Union Ave
Sudbury, MA 01776
(877) 783-6800
sales@methodsmachine.com
www.methodsmachine.com

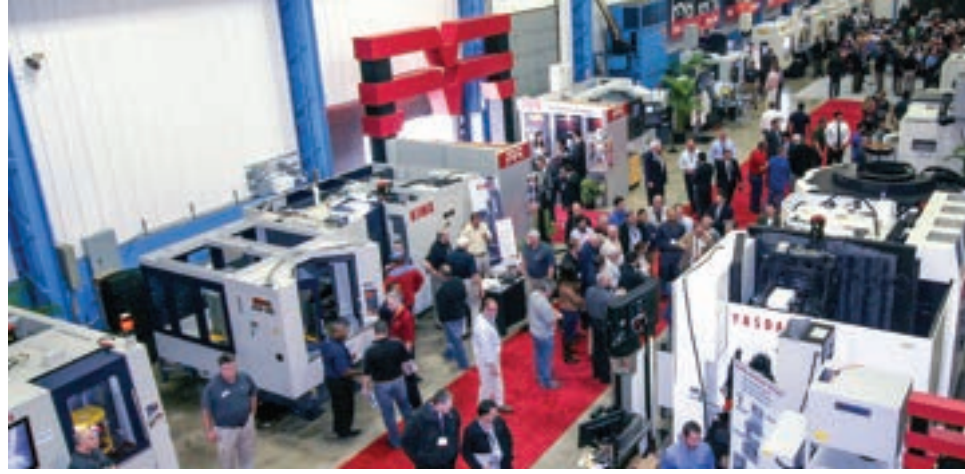

Founded in 1958, with three employees and a few refurbished machines, Methods Machine Tools, Inc. has grown into one of the largest, most innovative precision machine tools importers in North America. With over 300 employees, eight sales and technology centers, and over 40,000 machines installed throughout the United States, Canada and Mexico, Methods supplies leading-edge precision machine tools and solutions. The founder Mr. Clement McIver, Sr., established principles from the company's beginning that continue to set Methods apart from conventional importers or distributors. "Anyone can sell a machine," said the company's late founder, "but not everyone provides the extra effort that makes a difference in the company's bottom line."



Methods - Boston
65 Union Ave
Sudbury, MA 01776
(978) 443-5388



Methods - Charlotte*
13607 South Point Boulevard
Charlotte, NC 28273
(704) 587-0507



Methods - Chicago
2400 Vantage Drive
Elgin, IL 60124
(847) 783-6800



Methods - Detroit
50531 Varsity Court
Wixom, MI 48393
(248) 624-8601



Methods - Los Angeles
1980 West Corporate Way
Anaheim, CA 92801
(714) 521-2507



Methods - Memphis*
6700 Fletcher Creek Cove
Memphis, TN 38133
(901) 255-6760



Methods - Phoenix
615 West 24th Street
Tempe, AZ 85282
(602) 437-2220



Methods - San Francisco
650 Whitney Street
San Leandro, CA 94577
(510) 636-1430

*Limited Availability