

Higher accuracy  
produces  
greater profitability

A circular inset image showing a close-up of a machine spindle with a tool bit, rendered in a blue, wireframe-like style.

# YBM 10 T

YASDA PRECISION CENTER

Thermal Distortion Stabilized System  
High-performance Spindle with Preload Self-adjusting System  
All axes Twin screw Drive System

# YASDA

**5000kg**



**45m/min**

### Best Quality and Performance

YASDA Precision Center YBM 10T is a large size horizontal machining center, developing a new area for high speed and high precision machining of a large and heavy components.

The high speed positioning of 45m/min. is achieved employing twin ball screws for each linear axis remaining YASDA's traditional high positioning accuracy and the machine further increased its rigidity.

Excellent capability is achieved for high precision machining of box shape components and large size die and molds.

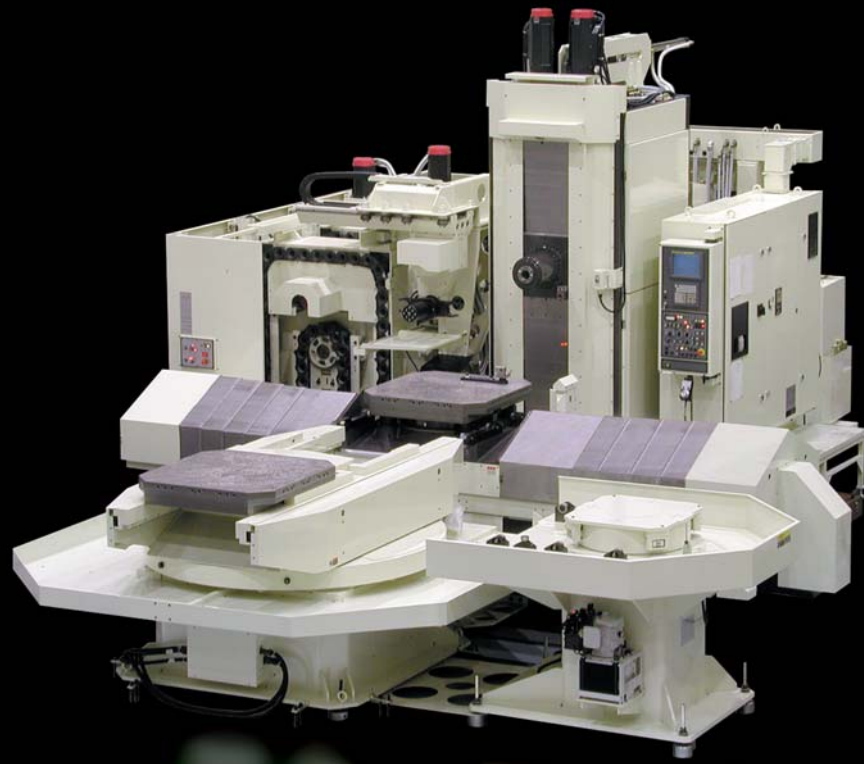

PRECISION CENTER **YBM 10T** RPC



PRECISION CENTER **YBM 10T** 5PLS

# Highly Accurate and Efficient Performance of YBM 10T

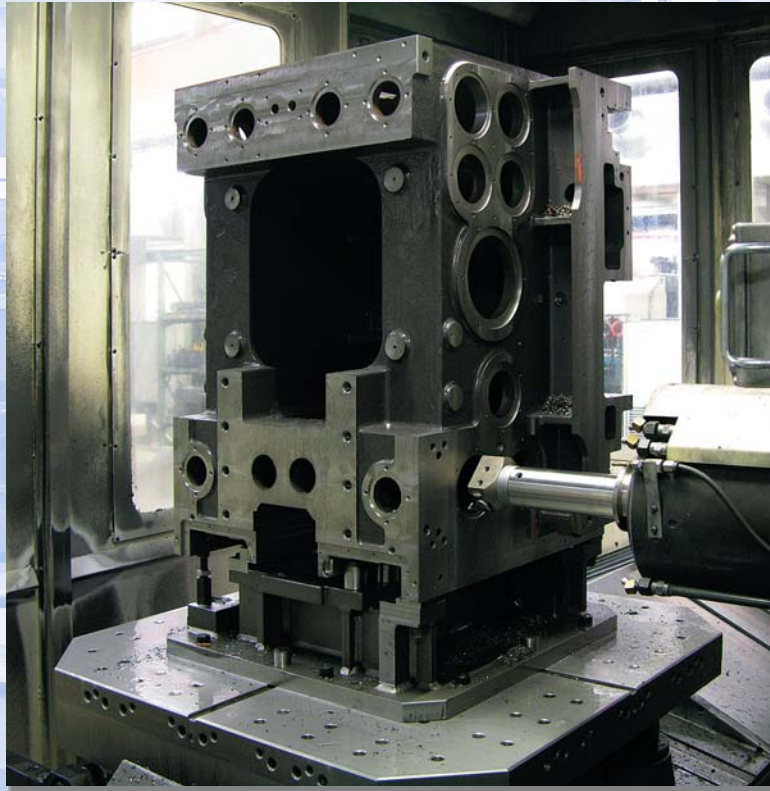

## Comparison of Previous model and YBM 10T

Work piece Saddle of vertical machining center		Machining time by previous model (hour)	Machining time by YBM 10T (hour)	Reduction of machining time in %
		YBM-120N-120RP-5PLS	YBM-10T-100RP-5PLS	
640V <sub>ver.</sub>	1st setting	4	3.2	20
	2nd setting	10	9	10
	3rd setting	5	4.3	14

Work piece Table of vertical machining center		Machining time by previous model (hour)	Machining time by YBM 10T (hour)	Reduction of machining time in %
		YBM-120N-120RP-5PLS	YBM-10T-100RP-5PLS	
950V <sub>ver.</sub>		17.8	10.8	39

— This data is a comparison in the Yasda workshop —

Outstanding Technology that enables the heaviest job on 1000x1000mm pallet in the world, of max. 5 tons with the highest accuracy

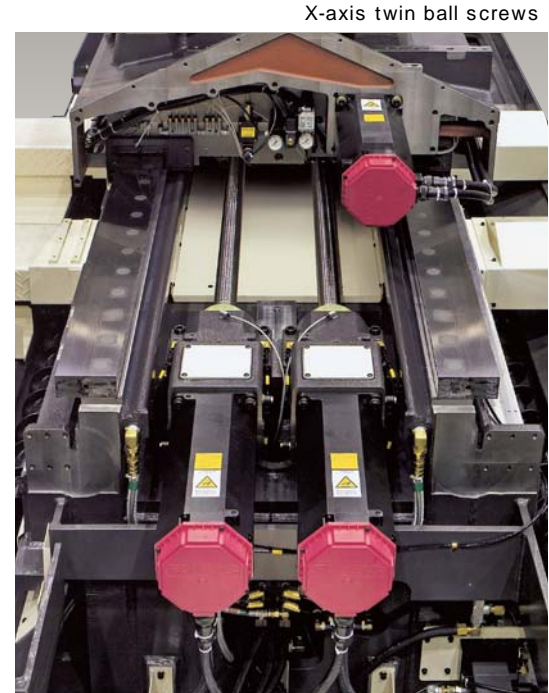
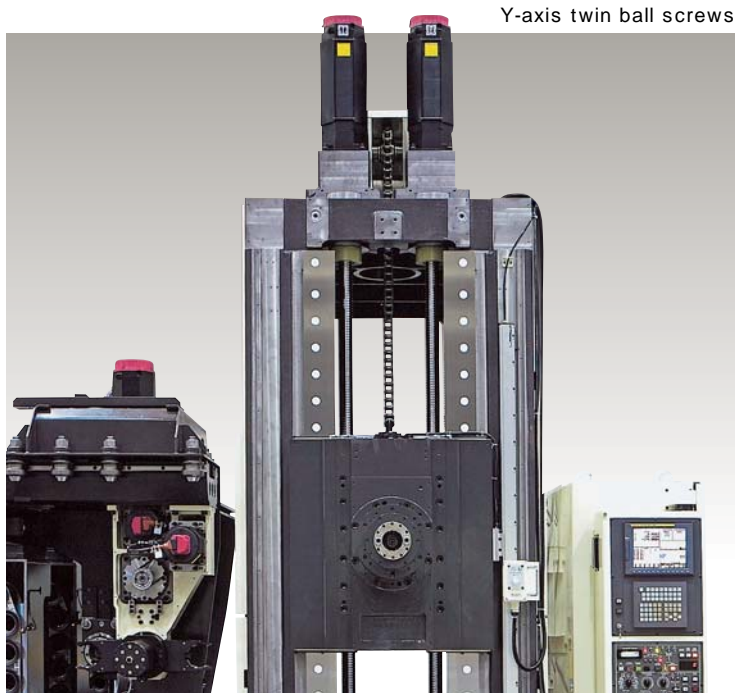

**1 Twin ball screws (X / Y / Z axis)**

By using twin ball screws on each linear axis, high speed positioning of 45m/min. is achieved without sacrificing high positioning accuracy and machine rigidity.

**2 B-axis employed big diameter 3 roller bearing**

By using the big diameter 3 roller bearing on B-axis highly accurate positioning of max. 5 tons on 1000x1000mm pallet rotation is achieved with high speed.

**3 Improved vertical movement and straightness of the spindle head**

The spindle head is positioned in the center of the two ball screws that improved geometrical accuracy of Y-axis and stable vertical movement of the spindle head.

**4 X-axis: Load sensing & Guide ways surface pressure control system**

In order to control a heavy component at high speed, the load sensing and guide ways surface pressure control system are employed on X-axis guide ways.

Positioning Accuracy of Y-axis

ISO 230/2( 1997 )

A (Positioning Uncertainty)	0.002812
R (Positional Scatter)	0.001821
B (Reversal Error)	0.000589

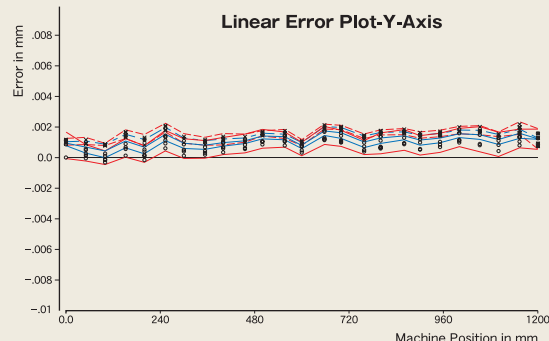

# Highly rigid machine construction that supports reliability and stability of the precision job

## BED

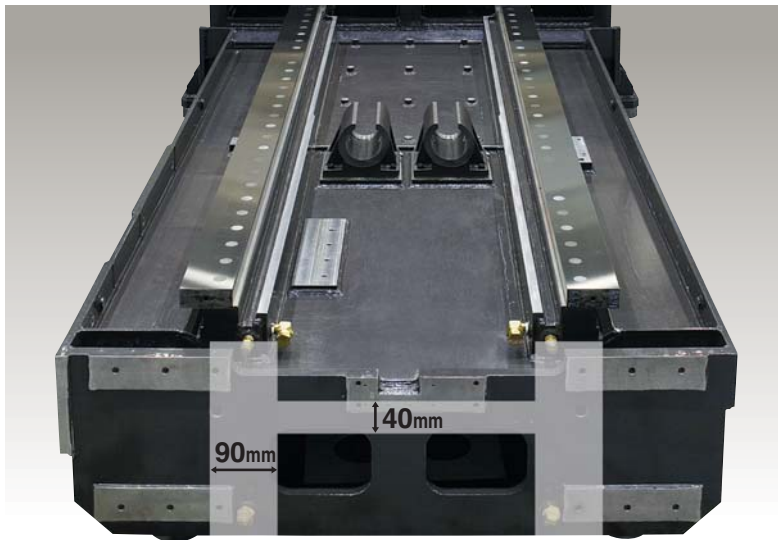

The steel bed of simple “H” configuration with two 90mm thick longitudinal frames and 40mm thick flat surface frame enabled outstanding rigidity.

Each solid steel sheet of the frame has an equal heat capacity at any point, therefore the bed is free from any strain caused by the room temperature changes, and assure high stability of geometrical accuracy.

## COLUMN

The large column with a double housing structure ensures outstanding thermal control and machine rigidity. Each housing is designed in the shape of box formed by double walls and ribs are arranged in the housing.

### Column (Y-axis) guide ways

Y-axis guide ways are mounted in a slight concave configuration in order the spindle head to obtain equal preload at any position of Y-axis. Combination with the roller way bearings on the both sides of the spindle head, it minimizes yawing error of the spindle head and stable high positioning accuracy is ensured.

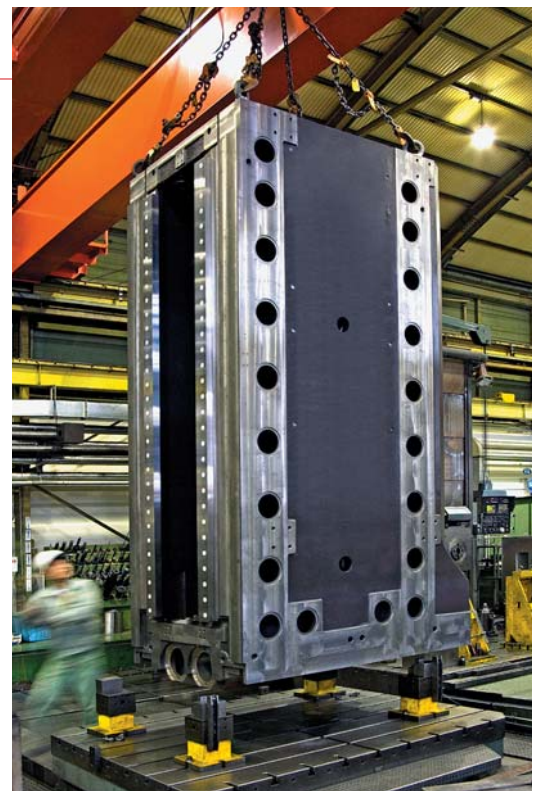
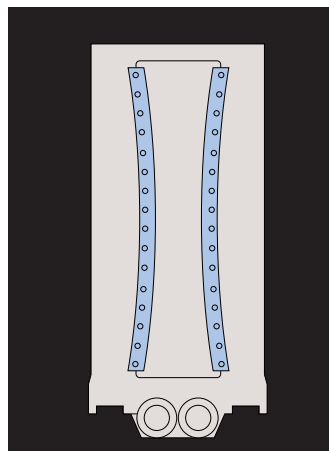

# PALLET & PALLET CHUCKING SYSTEM

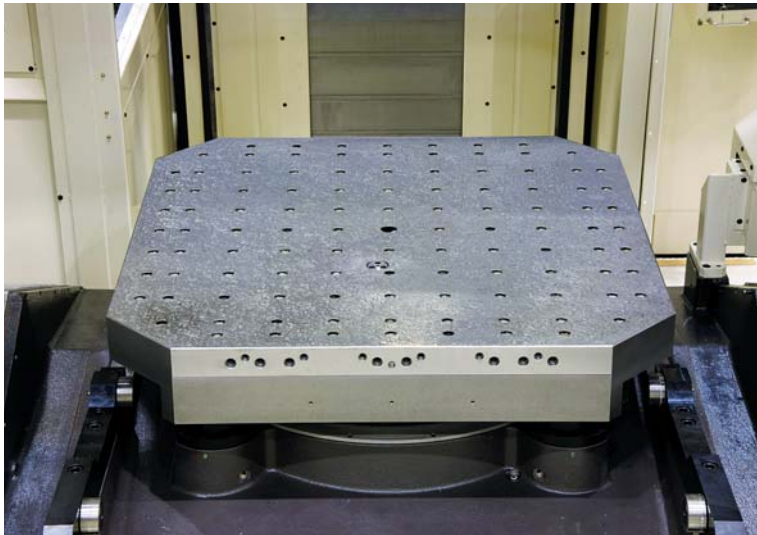

Highly rigid 120mm thickness pallet and the curvic coupling of large diameter ensure high accuracy of work pieces for long years.

The pallet is made of high quality cast iron, and its top surface is carefully hand scraped to support micron meter accuracy of work piece.

The bottom of the pallet is flat, and available for any kinds of transportation system, like automatic warehouse or FMS system.

Large diameter curvic coupling is employed on the pallet chucking system. This curvic coupling has 72 teeth with a 30 degree engaging angle on each tooth which engage without any backlash and automatically locates the center of the pallet.

## CLEANING NOZZLE FOR CURVIC COUPLING

Air cleaning nozzle is provided to the base of each tooth of the curvic coupling. The surface of the teeth is kept clean by ejected air from the nozzle, and it ensures high chucking accuracy all the time.



# SPINDLE

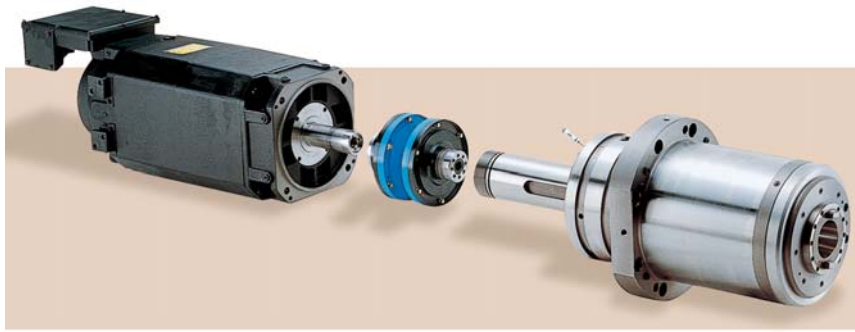

YASDA 's exclusive preload self-adjusting system technology provides a large preload at low speed, and reduces the preload according to the heat generated by higher spindle speed. This mechanism creates a clear advantage over the conventional fixed type preload system.

Appropriate preload for full range of the spindle speed help achieve the both heavy duty cutting at low spindle speed and highly accurate rotation at high spindle speed.

The spindle cartridge and the spindle motor are connected co-axially by a diaphragm coupling to achieve highly accurate rotation of the spindle at the full range of its rotation speed.

Variety of machining is possible by YASDA 's spindle, such as highly accurate turn boring, heavy duty machining, high speed machining on the hardened steel, helical end milling, back face milling, and so on.

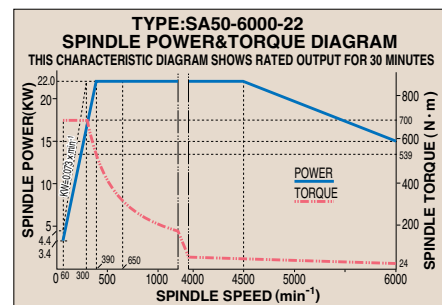
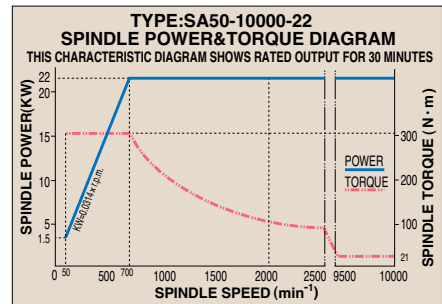

# ATC



Loading / unloading system of tool is option

## Tool Stocker

From 120 tools up to 450 tools ATC is selectable according to the customer's purpose. Together with the Tool holder cleaning system, the reliable ATC proved its high stability at many users with their FMS systems for long years.

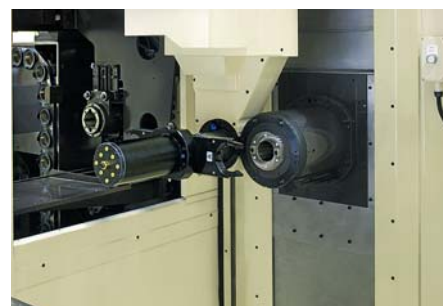

Automatic Tool Changer



# ACCURACY RETENTION SYSTEM

## THERMAL DISTORTION STABILIZING SYSTEM (Option)

Thermal distortion of the machine in geometry can occur when the room temperature changes in a short time, which is critical for high accuracy job.

YASDA Thermal distortion stabilizing system enables to keep the machine geometry stable against changes of the room temperature, that circulates a temperature controlled oil,  $\pm 0.2\text{ }^{\circ}\text{C}$  to room temperature, throughout the main structure of the machine.

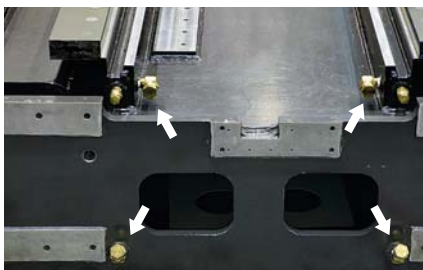

Thermal distortion stabilizing oil to the bed

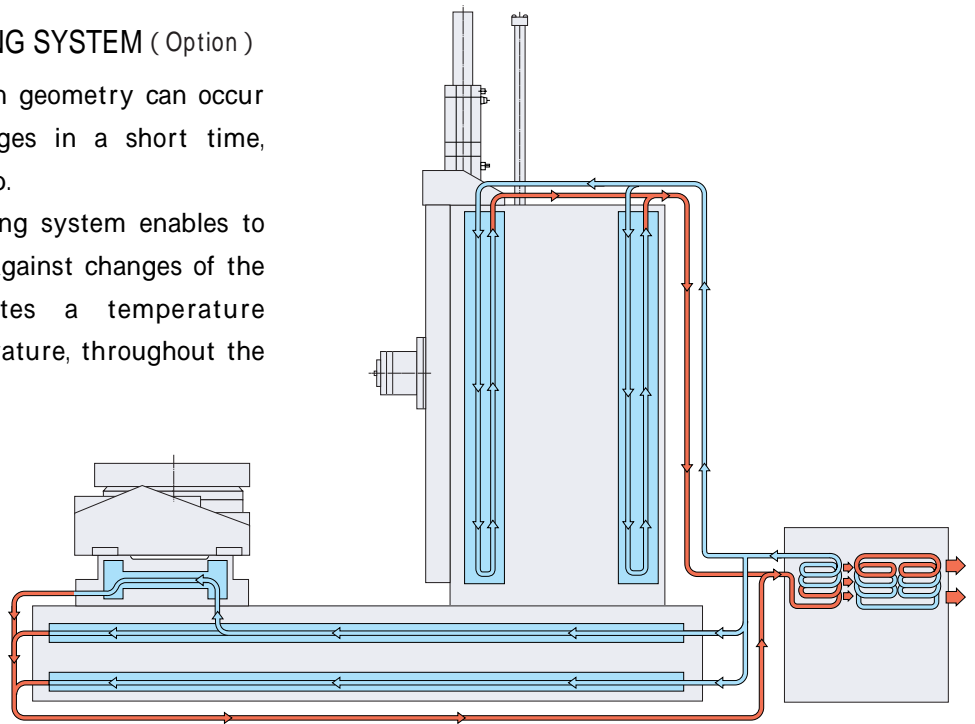

## HEAT TRANSMISSION PREVENTION ON THE BED

The guide ways and the bed are protected with a cover so that the warmed coolant after machining and chips dropped cannot affect on the thermal deformation of these main components.

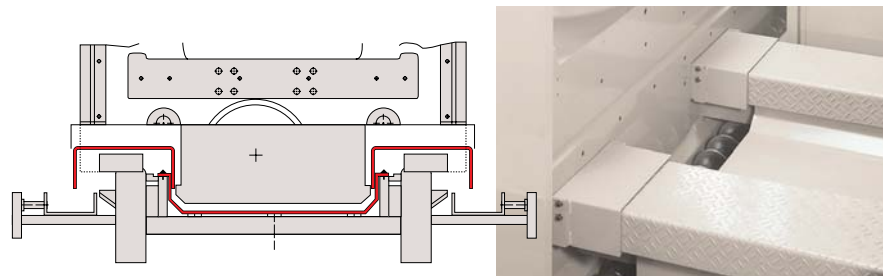

# BALL SCREW BRACKET

## COOLING SYSTEM OF BALL SCREW BRACKET

Cooling oil circulates through the oil jacket in the ball screw bracket that prevents heat generation of the thrust bearing and helps stabilize machine geometry during its running.

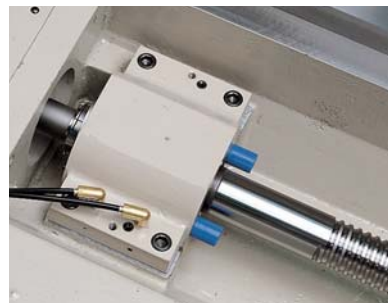
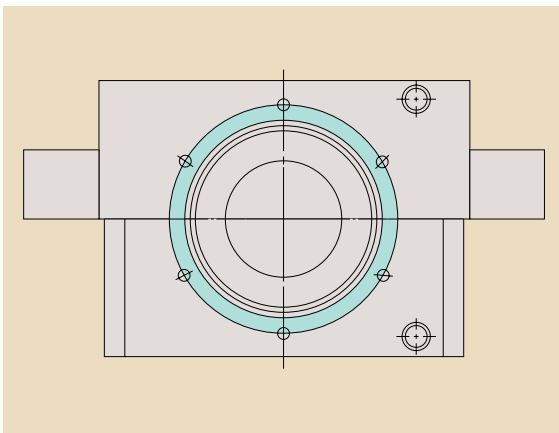

# OPTICAL SCALE FEEDBACK

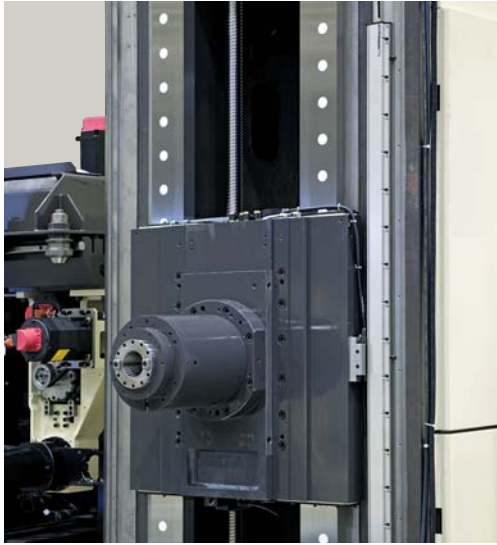

## OPTICAL SCALE FEEDBACK

The full closed loop type optical scale is employed for highly accurate positioning of linear axes. The scale is attached to the machine components in order not to create difference in temperature between the scale and the machine components.



YASDA MiPS: Creative control system (Option)

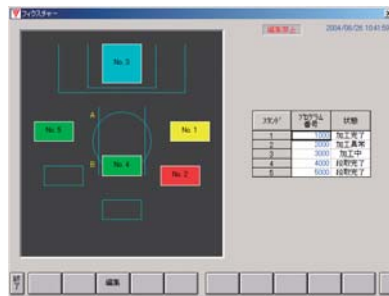

- ① Maintenance Displaying Function
- ② Self-Diagnosis Function
- ③ Management Function

The creative control system “YASDA MiPS” achieves high productivity and high automation, and has superior machine control capability with:

- “Maintenance Displaying Function,” easing daily maintenance program
- “Self-Diagnosis Function,” troubleshooting and displaying the location of malfunction
- “Management Function,” a tool management, machining load monitoring and production management system

The new “Machining Aid Function”  
This system is ready for networking.

# SPECIFICATIONS

## 1. Standard specifications of base machine

<b>1-1 Travel</b>	
X-axis travel (Longitudinal movement of table)	1500mm
Y-axis travel (Vertical movement of spindle head)	1200mm
Z-axis travel (Cross movement of column)	1100mm
Distance from table surface to spindle center	0 ~ 1200mm
Distance from table center to spindle nose face	200 ~ 1300mm
<b>1-2 Table</b>	
Max. swing dia. of workpiece	1350mm
Table loading capacity	5000kg
Min. table indexing angle	0.0001 °
Table indexing rapid rate	10min <sup>-1</sup>
Table indexing feed rate	4min <sup>-1</sup>
<b>1-3 Spindle</b>	
Model	SA50-10000-22 ( Preloads self-adjusting spindle )
Spindle speed range	50 ~ 10000min <sup>-1</sup>
Spindle drive motor (30min. rating)	AC18.5kW/22kW
Spindle nose taper	7/24 taper No50 (BT50)
Spindle bearing inner diameter	100mm
<b>1-4 Feedrate</b>	
Rapid traverse rate( X,Y,Z-axis )	45000mm/min
Feedrate( X,Y,Z-axis )	1 ~ 10000mm/min
<b>1-5 Mass of machine</b>	
	Approx.30000kg
<b>1-6 Electric power supply</b>	
	Max.92kVA

## 2. Standard equipments

<b>2-1 Numerical Control unit</b>	
<b>2-2 Pallet chucking device</b>	
<b>2-3 Automatic pallet changer</b>	1 L/U stand
<b>2-4 Pallet</b>	
Pallet size	1000 x 1000mm
Pallet surface configuration	M16 tapped holes at 100mm pitch
<b>2-5 Spindle head &amp; X, Y, Z-axis ball screw bracket oil cooling system</b>	
Cooling capacity	4160kcal/h
<b>2-6 Cutting oil unit( Wet type )</b>	
AA type : flat nozzles( M08 )	6 nozzles around spindle nose
Tank capacity	900L
<b>2-7 Splash guard( with automatic door &amp; slide roof )</b>	
Fluorescent light ( 1set )	40W
<b>2-8 Chip conveyor</b>	
	Twin-screw + hinge & scraper type chip conveyor with separator
<b>2-9 Hydraulic unit</b>	
Pump discharge / Pump output	105L/min / 9MPa
Oil reservoir	100L
<b>2-10 Way protector</b>	
<b>2-11 Optical scale feedback</b>	X,Y,Z-axis
<b>2-12 Rotary encoder feedback</b>	B-axis
<b>2-13 YASDA HAS-0 System</b>	
Feedrate	Max.10000mm/min
<b>2-14 Spindle speed &amp; tool number indicator</b>	

## 3. Optional equipments

<b>3-1 YASDA MiPS</b>	
	YASDA self-diagnosis function
	Maintenance support function

<b>3-2 X-axis stroke extension</b>	600mm/Total 2100mm
<b>3-3 Y-axis stroke extension</b>	200mm/Total 1400mm
<b>3-4 High-speed spindle</b>	
Model	SA50-15000-30( Preload self-adjusting spindle )
Spindle speed ranges	50 ~ 15000min <sup>-1</sup>
Spindle drive motor (30min. rating)	AC22kW/30kW
Spindle nose taper	7/24 taper No.50 ( BT50 )
Spindle bearing inner diameter	95mm
<b>3-5 Automatic tool stocker</b>	
Tool number	90 ~ 450 tools
Type of tool shank	MAS-403 BT50
Type of pull stud	MAS-403 P50T-1( 45 °)
Tool selection system	Random selection by address system
Max. dia. of tool	300mm
Max. length of tool	440mm
Max. mass of tool	20kg
Max. tool dia. of full setting	100mm
Distance pot and put on magazine	115mm
<b>3-6 Preload stand( PLS )</b>	
Number of pallet stand	5
Pallet rotation device	360 rotation( power assisted )
Automatic program search	Equipped
<b>3-7 Pallet</b>	
Pallet size	1250 x 1250mm
Pallet surface configuration	M16 tapped holes at 100mm pitch
<b>3-8 Thermal distortion stabilizing system</b>	
Range of temperature control	Ref. temperature ± 0.2 C
Cooling capacity	3800kcal/h ( 50Hz )
Heating capacity	1720kcal/h ( 2kW )
Amount of circulating oil	200L/min
Tank capacity	400L( Total 1000L )
Weekly timer	Equipped
<b>3-9 Coolant shower unit</b>	
	from the ceiling
<b>3-10 High pressure cutting oil unit ( Spindle center through type )</b>	
Pump output	3.5MPa ( 35kgf/cm <sup>2</sup> )
	6MPa ( 60kgf/cm <sup>2</sup> )
Pump discharge	20L/min
<b>3-11 Cutting oil temperature control unit</b>	
Temperature control	± 5
Tank capacity	120L
<b>3-12 Spindle center through air coolant unit</b>	
<b>3-13 Spindle center through micro-fog coolant unit</b>	
<b>3-14 External cyst coolant unit</b>	2 nozzles around spindle nose
<b>3-15 Tool management function</b>	
<b>3-16 Stored tooling content confirmation system ( MiPS )</b>	
<b>3-17 Automatic tool length/radius compensation system &amp; tool breakage sensing system</b>	
<b>3-18 Auto-measuring system</b>	
<b>3-19 YASDA HAS-3 System</b>	
Feedrate	Max.10000mm/min
<b>3-20 Anchor unit</b>	

\* Specifications are subject to alteration or change without notice and obligation on the part of the manufacturer.

## OUT LINE

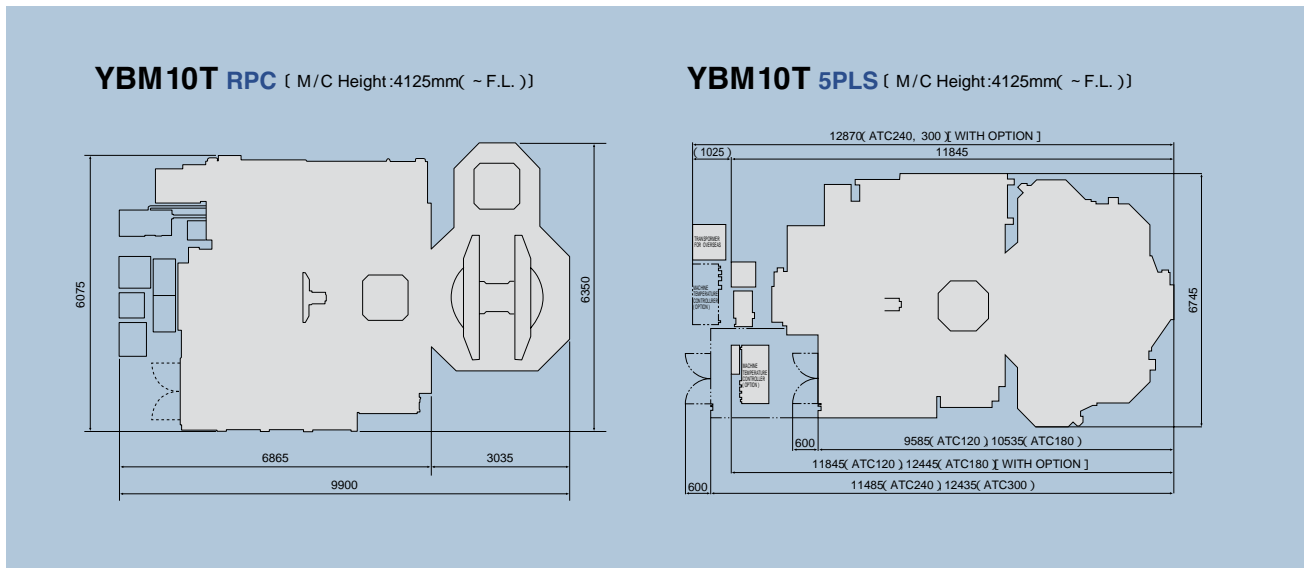

# YASDA

**YASDA PRECISION TOOLS K.K.**

URL <http://www.yasda.co.jp>

Main Office & Factory:

1160 Hamanaka, Satoshicho, Okayama, 719-0303, Japan  
PHONE: +81/865-64-2511 FAX: +81/865-64-4535

Representative Office:

Firtz-Vomfelde Strasse 34, D-40547 Düsseldorf, Germany  
PHONE: +49/211-53-883214 FAX: +49/211-53-883112

**YASDA PRECISION AMERICA CORPORATION**

URL <http://www.yasda.com>

751 Landmeier Road Elk Grove Village, IL 60007, U.S.A.  
PHONE: +1/847-439-0201 FAX: +1/847-439-0260